

COMPETENCE BASED CURRICULUM

SENIOR SCHOOL

GRADE 10

GRADE GUIDE NOTES

ELECTRICAL TECHNOLOGY

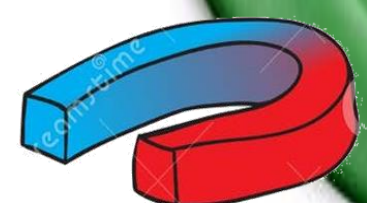
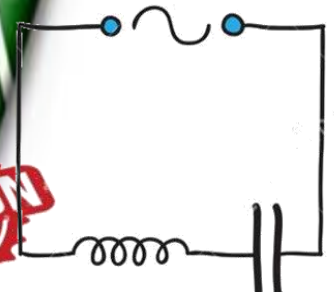
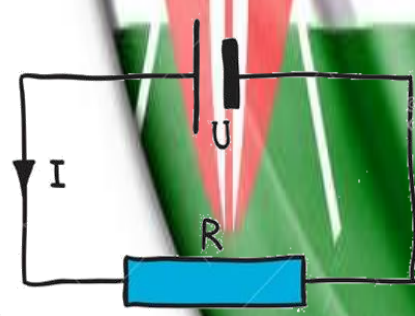
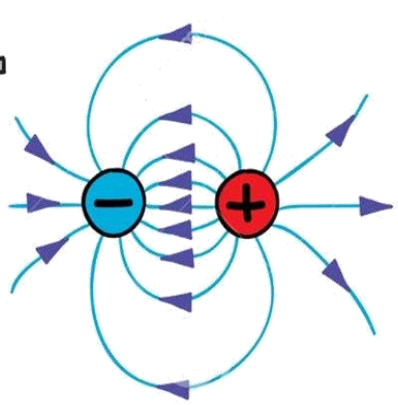
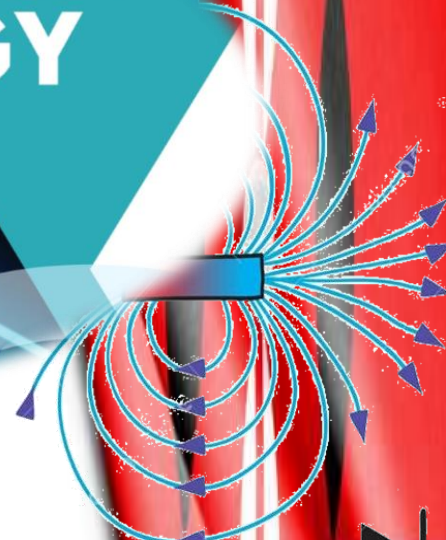
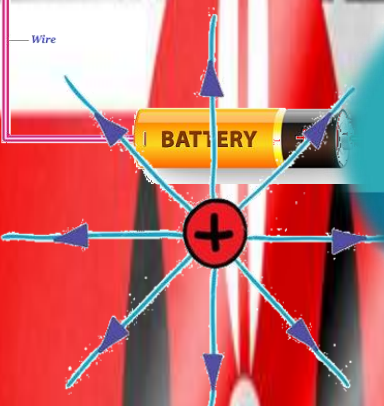

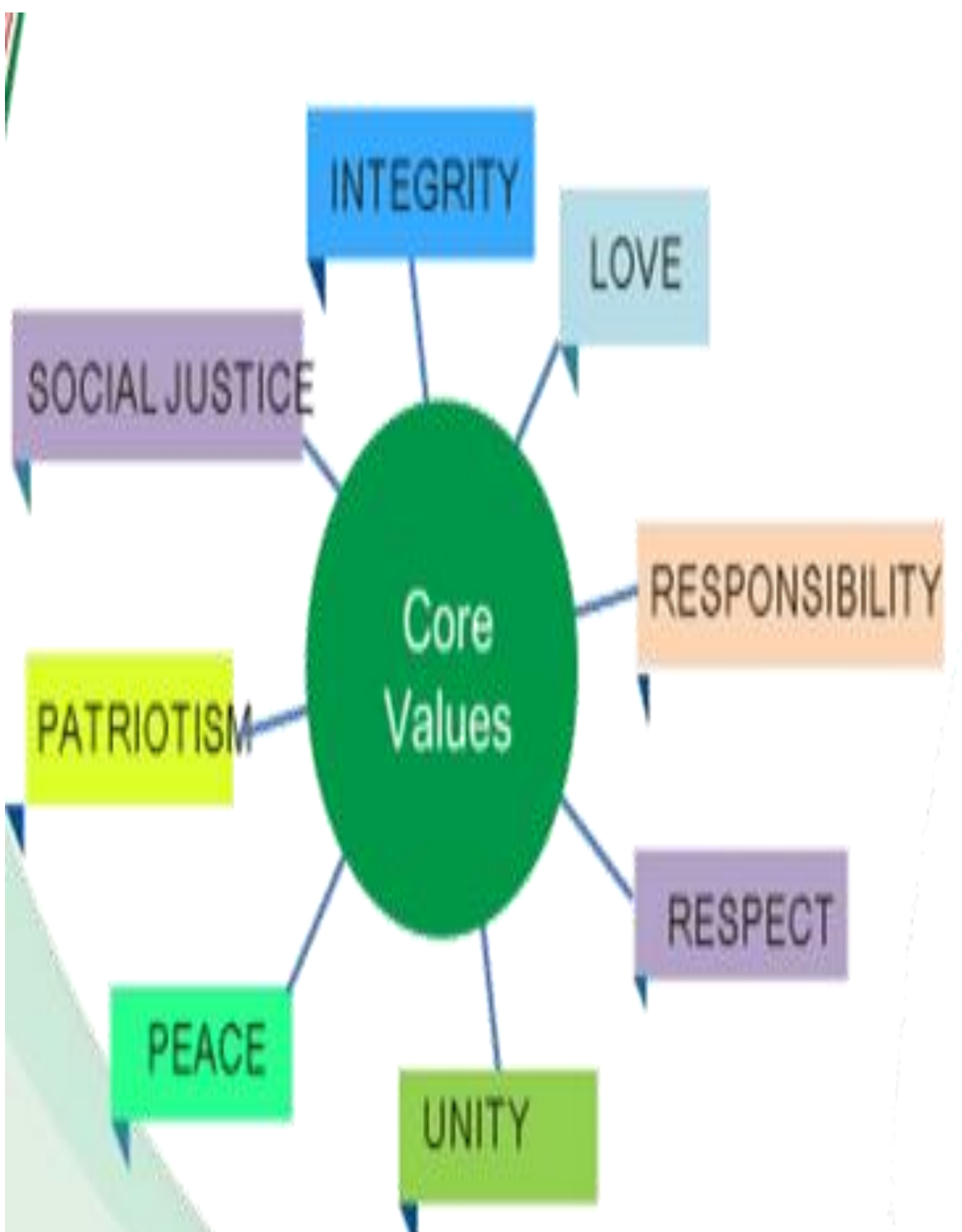

INTEGRITY

LOVE

RESPONSIBILITY

RESPECT

UNITY

PEACE

PATRIOTISM

SOCIAL JUSTICE

Core Values



Communication and
Collaboration



Critical Thinking
and Problem
Solving



Digital
Literacy



Imagination and
Creativity



Citizenship



New Kenya Basic Education Curriculum Framework

2 - 6 - 6 - 3

Pre - Primary School - 2 Yrs.

Pre-Primary 1

Pre-Primary 2

Formative Assessment

Lower Primary School - 3 Yrs.

Grade 1

Grade 2

Grade 3

Formative Assessment and
National Assessment

Upper Primary School - 3 Yrs.

Grade 4

Grade 5

Grade 6

Formative Assessment and
National Assessment

Lower Secondary School - 3 Yrs.

Grade 7

Grade 8

Grade 9

Formative Assessment and
National Assessment

Senior Secondary School - 3 Yrs.

Grade 10

Grade 11

Grade 12

Formative Assessment and
National Assessment

Tertiary and Higher Education
3 Years

- ❑ **Formative Assessments** - Ongoing throughout term/semester
- ❑ **National Assessments** - Summative - end of lower and upper primary education, lower secondary education and senior school. For placement and certification

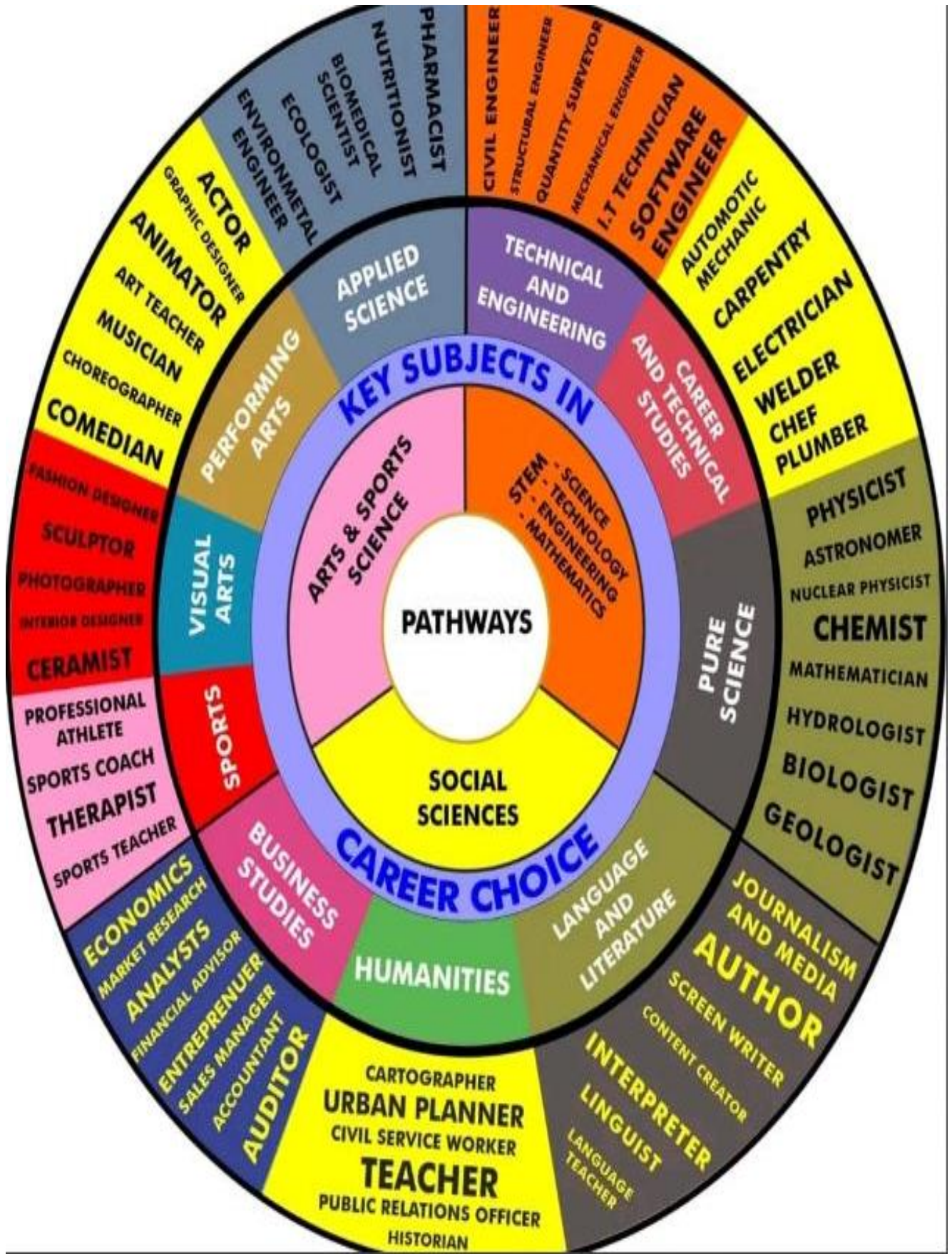

LIST OF LEARNING AREAS AT SENIOR SCHOOL

Compulsory Subjects	Science, Technology, Engineering & Mathematics (STEM)	Social Sciences	Arts & Sports Sciences
1. English	5. Mathematics/Advanced Mathematics	22. Advanced English	36. Sports and Recreation
2. Kiswahili/KSL	6. Biology	23. Literature in English	37. Physical Education (C)
3. Community Service Learning	7. Chemistry	24. Indigenous Language	38. Music and Dance
4. Physical Education	8. Physics	25. Kiswahili Kipevu/Kenya Sign Language	39. Theatre and Film
	9. General Science	26. Fasihi ya Kiswahili	40. Fine Arts
	10. Agriculture	27. Sign Language	
	11. Computer Studies	28. Arabic	
	12. Home Science	29. French	
	13. Drawing and Design	30. German	
	14. Aviation Technology	31. Mandarin Chinese	
	15. Building and Construction	32. History and Citizenship	
	16. Electrical Technology	33. Geography	
	17. Metal Technology	34. Christian Religious Education/ Islamic Religious Education/Hindu Religious Education	
	18. Power Mechanics	35. Business Studies	
	19. Wood Technology		
	20. Media Technology*		
	21. Marine and Fisheries Technology*		

NB: ICT skills will be offered to all students to facilitate learning and enjoyment

LESSON DISTRIBUTION AT SENIOR SCHOOL

The number of lessons in each of the compulsory learning areas shall be 4; while the optional areas shall be 6 lessons each. A lesson shall be 40 minutes. The "**free**" lessons shall be used for development of ICT skills, Pastoral Instruction Programme (PPI), projects, collaborative study and further reading.

NATIONAL GOALS OF EDUCATION

Education in Kenya should:

1. Foster nationalism and patriotism and promote national unity.

Kenya's people belong to different communities, races and religions, but these differences need not divide them. They must be able to live and interact as Kenyans. It is a paramount duty of education to help young people acquire this sense of nationhood by removing conflicts and promoting positive attitudes of mutual respect which enable them to live together in harmony and foster patriotism in order to make a positive contribution to the life of the nation.

2. Promote the social, economic, technological and industrial needs for national development.

Education should prepare the youth of the country to play an effective and productive role in the life of the nation.

a) Social Needs

Education in Kenya must prepare children for changes in attitudes and relationships which are necessary for the smooth progress of a rapidly developing modern economy. There is bound to be a silent social revolution following in the wake of rapid modernization. Education should assist our youth to adapt to this change.

b) Economic Needs

Education in Kenya should produce citizens with the skills, knowledge, expertise and personal qualities that are required to support a growing economy. Kenya is building up a modern and independent economy which is in need of an adequate and relevant domestic workforce.

c) Technological and Industrial Needs

Education in Kenya should provide learners with the necessary skills and attitudes for industrial development. Kenya recognizes the rapid industrial and technological changes taking place, especially in the developed world. We can only be part of this development if our education system is deliberately focused on the knowledge, skills and attitudes that will prepare our young people for these changing global trends.

3. Promote individual development and self-fulfilment

Education should provide opportunities for the fullest development of individual talents and personality. It should help children to develop their potential interests and abilities. A vital aspect of individual development is the building of character.

4. Promote sound moral and religious values.

Education should provide for the development of knowledge, skills and attitudes that will enhance the acquisition of sound moral values and help children to grow up into self-disciplined, self-reliant and integrated citizens.

5. Promote social equality and responsibility.

Education should promote social equality and foster a sense of social responsibility within an education system which provides equal educational opportunities for all. It should give all children varied and challenging opportunities for collective activities and corporate social service irrespective of gender, ability or geographical environment.

6. Promote respect for and development of Kenya's rich and varied cultures.

Education should instill in the youth of Kenya an understanding of past and present cultures and their valid place in contemporary society. Children should be able to blend the best of traditional values with the changing requirements that must follow rapid development in order to build a stable and modern society.

7. Promote international consciousness and foster positive attitudes towards other nations.

Kenya is part of the international community. It is part of the complicated and interdependent network of peoples and nations. Education should therefore lead the youth of the country to accept membership of this international community with all the obligations and responsibilities, rights and benefits that this membership entails.

8. Promote positive attitudes towards good health and environmental protection.

Education should inculcate in young people the value of good health in order for them to avoid indulging in activities that will lead to physical or mental ill health. It should foster positive attitudes towards environmental development and conservation. It should lead the youth of Kenya to appreciate the need for a healthy environment.

LEVEL LEARNING OUTCOMES

By the end of Senior School, the learner should be able to:

1. Communicate effectively and utilise information and communication technology across varied contexts.
2. Apply mathematical, logical and critical thinking skills for problem solving.
3. Apply basic research and scientific skills to manipulate the environment and solve problems.
4. Exploit individual talents for leisure, self-fulfilment, career growth, further education and training.
5. Uphold national, moral and religious values and apply them in day to day life.
6. Apply and promote health care strategies in day to day life.
7. Protect, preserve and improve the environment for sustainability.
8. Demonstrate active local and global citizenship for harmonious co-existence.
9. Demonstrate appreciation of diversity in people and cultures.
10. Manage pertinent and contemporary issues responsibly.

THE SENIOR SCHOOL IN THE COMPETENCY BASED CURRICULUM (CBC)

Senior School is the fourth level of Basic Education in the Competency Based Curriculum (CBC) that learners shall come to after the Pre-Primary, Primary and Junior School (JS). The essence of Senior School is to offer learners a Pre-University/ Pre-career experience where the learners have an opportunity to choose pathways where they have demonstrated interest and/or potential at the earlier levels. Senior school comprises three years of education for learners in the age bracket of **15 to 18 years** and lays the foundation for further education and training at the tertiary level and the world of work. In the CBC vision, learners exiting this level are expected to be **engaged, empowered and ethical citizens** ready to participate in the socio-economic development of the nation.

At this level, learners shall take **SEVEN (07) learning areas (LAs)** as recommended by the *Presidential Working Party on Educational Reforms (PWPER)*. These shall comprise **Four Compulsory** learning areas, and Three learning areas opted for by the learner according to their chosen Pathway. While English and Kiswahili are indicated as Compulsory, the learners who opt for these learning areas as their subjects of specialization shall go through a *differentiated curriculum* in terms of scope, experiences and assessment. Such learners shall; therefore, take *Advanced English* or *Kiswahili Kipevu* with additional two lessons. It is recommended that AT LEAST TWO learning areas should be from chosen Pathway. In exceptional cases, some learners may opt for ONE learning area from the chosen Pathway and a maximum of TWO learning areas from any of the three pathways; depending on the learner's career projections and with guidance by the principals at Senior School.

LESSON DISTRIBUTION AT SENIOR SCHOOL

The number of lessons in each of the compulsory learning areas shall be 4; while the optional areas shall be 6 lessons each. A lesson shall be 40 minutes. The "free" lessons shall be used for development of ICT skills, Pastoral Instruction Programme (PPI), projects, collaborative study and further reading.

ESSENCE STATEMENT

Electricity is an essential form of energy in the modern world. People use electricity for lighting, heating, air conditioning, refrigeration and for powering appliances like computers, electronics, and transportation systems. The continuing connectivity of electricity across Kenya and beyond requires sustained technical labour supply. This justifies the need to offer Electrical Technology as a subject in Senior Secondary Schools to help orient learners towards the development of a skilled workforce in electrical technology.

Electrical technology forms part of the STEM education and training discipline. STEM has been prioritised in the Kenya Vision 2030 as well as Sessional Paper No. 1 of 2019 as being pivotal in the development of Science, Technology and Innovation for human capital development. Electrical technology as a subject at Senior Secondary School builds on the competencies developed in Pre-Technical studies and Integrated Science at Junior School. It equips the learner with competencies of analysis, installation and maintenance of electrical and electronic equipment.

It is envisaged that this subject will provide an opportunity to gain knowledge, practical skills, attitudes and values that will enable the learner to use electricity and electrical appliances competently. It will also prepare the learner to either pursue further training in middle level colleges and universities in such courses as electrical engineering, mechatronics, telecommunication, communication electronics, industrial electronics, power engineering or join the world of work as an electrical wireman or fitter.

SUBJECT GENERAL LEARNING OUTCOMES

By the end of Senior School, the learner should be able to:

1. Observe personal safety, safety of tools, equipment and machines in the practice of electrical engineering works.
2. Analyse, design, and construct electric circuits.
3. Troubleshoot and fix faults in electrical and electronic systems.
4. Apply appropriate communication skills across varied settings and audiences in interpretation of Electrical Engineering works.
5. Practise good citizenship in waste management and ethical use of electronic and electrical technology.
6. Adhere to the established standards and regulations in Electrical Technology to uphold professional and ethical practices.
7. Utilise acquired skills, knowledge and attitude for career growth and further education and training in electrical engineering.
8. Appreciate electrical technology in the socio-economic development of the country.

SUMMARY OF STRANDS AND SUB STRANDS

1. FUNDAMENTALS OF ELECTRICAL TECHNOLOGY

- 1.10.1 Introduction to Electrical Technology
- 1.10.2 D.C Electric Circuit
- 1.10.3 Capacitors and Capacitance
- 1.10.4 Cells and Batteries

2. Electrical Machines

- 2.10.1 Magnetism
- 2.10.2 Electromagnetism
- 2.10.3 Measuring Instruments

3. Electrical Installation.

- 3.10.1 Generation, Transmission and Distribution of Electricity
- 3.10.2 Equipment at the Intake Point
- 3.10.3 Final Circuits

4. Electronics

- 4.10.1 Semiconductor Theory
- 4.10.2 Semiconductor Diodes
- 4.10.3 Transistors

STRAND 1.0: FUNDAMENTALS OF ELECTRICAL TECHNOLOGY

Sub-strand 1.0: Introduction to Electrical Technology

a) Importance of Electrical Technology in Society:

Electrical technology is fundamental to modern society. It powers our homes, industries, transportation, and communication systems.

✚ Domestic Uses:

- ✓ Lighting: Providing illumination in homes, schools, and streets.
- ✓ Appliances: Operating refrigerators, washing machines, cookers, and entertainment systems.
- ✓ Heating and Cooling: Regulating indoor temperatures with air conditioners and heaters.



✚ Industrial Uses:

- ✓ Manufacturing: Powering machinery and automation systems.
- ✓ Construction: Operating power tools and equipment.
- ✓ Mining: Running heavy machinery and extraction processes.



✚ Transportation:

- ✓ Electric vehicles (EVs) and trains.
- ✓ Electric bale vehicles

- ✓ Traffic management systems.

✚ **Communication:**

- ✓ Powering telecommunications networks, internet infrastructure, and electronic devices.



✚ **Healthcare:**

- ✓ Operating medical equipment, diagnostic tools, and life support systems.

✚ **Agriculture:**

- ✓ Irrigation systems, lighting for greenhouses, and powering farm machinery.

b) Career Opportunities in Electrical Technology:

- ✓ **Electrician:** Installing, maintaining, and repairing electrical systems in buildings and industries.



- ✓ **Electrical Engineer:** Designing and developing electrical systems, power generation, and distribution networks.



- ✓ **Electronics Technician:** Repairing and maintaining electronic equipment.
- ✓ **Power Plant Operator:** Monitoring and controlling power generation systems.
- ✓ **Telecommunications Technician:** Installing and maintaining communication networks.
- ✓ **Renewable Energy Technician:** Installing and maintaining solar, wind, and other renewable energy systems.
- ✓ **Automation and Control Technician:** Working on industrial automation systems.

c) Safety Regulations in Electrical Tasks:

- ✓ **Personal Protective Equipment (PPE):**
 - Insulated gloves: Protecting hands from electric shock.
 - Safety glasses: Protecting eyes from sparks and debris.
 - Safety shoes: Protecting feet from electrical hazards and falling objects.



- ✓ **Lockout/Tagout Procedures:** Ensuring circuits are de-energized before work begins.
- ✓ **Proper Tool Usage:** Using insulated tools and equipment.
- ✓ **Safe Work Practices:** Avoiding contact with live wires, maintaining a clean workspace, and following safety guidelines.
- ✓ **Awareness of electrical hazards.**

d) Roles of Stakeholders in Electrical Safety:

- **Kenya Power (KPLC):**
 - ✓ Responsible for the distribution and retail of electricity.
 - ✓ Ensures the safety of its infrastructure and connections.
 - ✓ Plays a vital role in public awareness campaigns regarding electrical safety.
 - ✓ Must adhere to safety regulations and standards.
 - ✓ They also have policies in place regarding stakeholder engagement, to ensure the safety of the public.

- **Kenya Electricity Transmission Company Limited (KETRACO):**
 - ✓ Focuses on the transmission of high-voltage electricity.
 - ✓ Prioritizes the safety of its transmission lines and substations.
 - ✓ Has a responsibility to provide a safe working environment for its employees and contractors.
 - ✓ They also must ensure that their operations do not put the public at risk.

- **Energy and Petroleum Regulatory Authority (EPRA):**
 - ✓ The regulatory body overseeing the energy sector.
 - ✓ Sets and enforces electrical safety standards and regulations.
 - ✓ Conducts inspections and audits to ensure compliance.
 - ✓ Investigates electrical accidents and incidents.

- **Government Agencies:**
 - ✓ The Ministry of Energy: Formulates energy policies and strategies, including those related to safety.
 - ✓ County governments: Play a role in enforcing building codes and electrical installation regulations at the local level.
 - ✓ The government is responsible for creating and enforcing the legal framework that electrical companies must follow.

- **Electrical Contractors and Technicians:**
 - ✓ Responsible for safe electrical installations and repairs.
 - ✓ Must adhere to industry standards and regulations.
 - ✓ Should be licensed and qualified to perform electrical work.
 - ✓ They are the ones who are on the ground performing the electrical work, so they must be well trained.

- **Consumers (Public):**
 - ✓ Responsible for using electricity safely in their homes and businesses.
 - ✓ Should be aware of electrical hazards and take precautions.
 - ✓ Should report any electrical safety concerns to the relevant authorities.
 - ✓ Public education is a very important part of electrical safety.

- **Educational and Training Institutions:**
 - ✓ Provide training and education on electrical safety to professionals and the public.
 - ✓ Help to develop a skilled workforce that understands and practices safe electrical work.
- **Industry Associations:**
 - ✓ These associations help to develop and promote best practices for electrical safety within the industry.

Key Aspects of Stakeholder Involvement:

- ❖ **Regulation and Enforcement:** EPRA's role in setting and enforcing standards is critical.
- ❖ **Infrastructure Safety:** KPLC and KETRACO must maintain safe infrastructure.
- ❖ **Public Awareness:** Educating the public about electrical hazards is essential.
- ❖ **Skilled Workforce:** Training and licensing qualified electricians is vital.
- ❖ **Workers:** Following safety regulations, using PPE, and reporting hazards.
- ❖ **Employers:** Providing safe working conditions, training, and PPE.
- ❖ **Government Agencies:** Enforcing safety standards and regulations.
- ❖ **Professional organizations:** Creating and updating safety standards.

Sub-strand 1.2: D.C Circuits

a) Properties of Resistors in DC Circuits:

- **Resistance (R):**
 - ✓ The opposition to the flow of electric current, measured in ohms (Ω).
 - ✓ Resistors limit current and control voltage in circuits.
 - ✓ Types of resistors: carbon, wirewound, variable (potentiometers, rheostats).

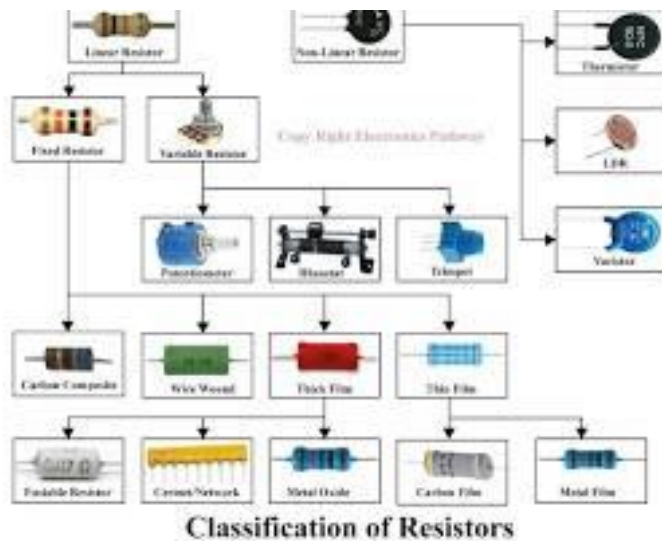

- **Ohm's Law:**
 - ✓ Relates voltage (V), current (I), and resistance (R): $V=IR$.

- ✓ This law is fundamental to analyzing DC circuits.
- **Power Dissipation:**
 - ✓ Resistors dissipate electrical power as heat: $P=IV=I^2R=V^2/R$.
 - ✓ Power rating of a resistor indicates the maximum power it can safely dissipate.
- **Color Codes:**
 - ✓ Resistors are marked with color bands to indicate their resistance value and tolerance.

Color	0	0	x1	
Brown	1	1	x10	±1%
Red	2	2	x10 ²	±2%
Orange	3	3	x10 ³	±3%
Yellow	4	4	x10 ⁴	±4%
Green	5	5	x10 ⁵	±0.5%
Blue	6	6	x10 ⁶	±0.25%
Violet	7	7	x10 ⁷	±0.1%
Grey	8	8	x10 ⁸	±0.05%
White	9	9	x10 ⁹	

b) Analyze DC Circuits Using Circuit Laws:

- **Ohm's Law:**
 - ✓ $V=IR$ (Voltage = Current × Resistance)
- **Kirchhoff's Laws:**
 - ✓ **Kirchhoff's Current Law (KCL):** The total current entering a junction is equal to the total current leaving the junction.
 - ✓ **Kirchhoff's Voltage Law (KVL):** The algebraic sum of the voltages in a closed loop is zero.
 - ✓ These laws are essential for analyzing complex DC circuits.
- **Series Circuits:**
 - ✓ Resistors are connected end-to-end.
 - ✓ Total resistance: $R_T=R_1+R_2+R_3+\dots$
 - ✓ Current is the same through all resistors.
 - ✓ Voltage is divided across resistors.

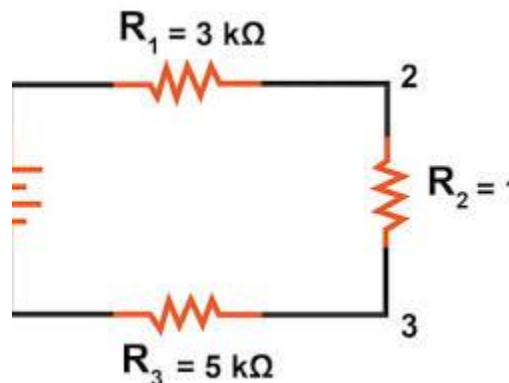

- **Parallel Circuits:**

- ✓ Resistors are connected side-by-side.
- ✓ Total resistance: $1/R_T = 1/R_1 + 1/R_2 + 1/R_3 + \dots$
- ✓ Voltage is the same across all resistors.
- ✓ Current is divided among resistors.

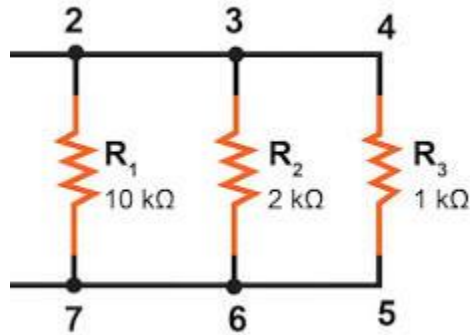

c) Construct Resistor Networks in DC Circuits:

- **Series Resistor Networks:**
 - ✓ Use breadboards or PCBs to connect resistors in series.
 - ✓ Measure total resistance and voltage drops.
- **Parallel Resistor Networks:**
 - ✓ Use breadboards or PCBs to connect resistors in parallel.
 - ✓ Measure total resistance and current division.
- **Combination Networks:**
 - ✓ Combine series and parallel connections to create more complex circuits.
 - ✓ Use Ohm's Law and Kirchhoff's Laws to analyze the circuits.

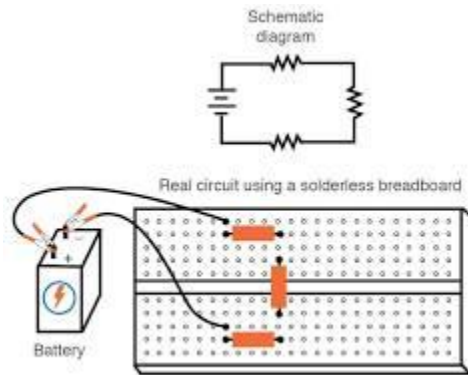

d) Troubleshoot DC Circuits in Electrical Appliances:

- **Fault Identification:**
 - ✓ Open circuits: Break in the circuit, no current flow.
 - ✓ Short circuits: Unintended path for current, excessive current flow.
 - ✓ Faulty components: Resistors, capacitors, diodes, etc.

- ✓ Dry joints: Poor solder connections.
- ✓ Loose terminals: Loose wire connections.
- **Troubleshooting Tools:**
 - ✓ Multimeter: Measuring voltage, current, and resistance.
 - ✓ Continuity tester: Checking for breaks in circuits.



- **Troubleshooting Techniques:**
 - ✓ Visual inspection.
 - ✓ Voltage measurements.
 - ✓ Resistance measurements.
 - ✓ Component testing.

e) Practical Applications of DC Circuits in Day-to-Day Life:

- **Home Automation:**
 - ✓ Lighting control systems.
 - ✓ Thermostats and HVAC systems.
 - ✓ Security systems.



- **Car Safety Applications:**
 - ✓ Automotive lighting systems.
 - ✓ Sensors and control systems.
 - ✓ Electronic control units (ECUs).

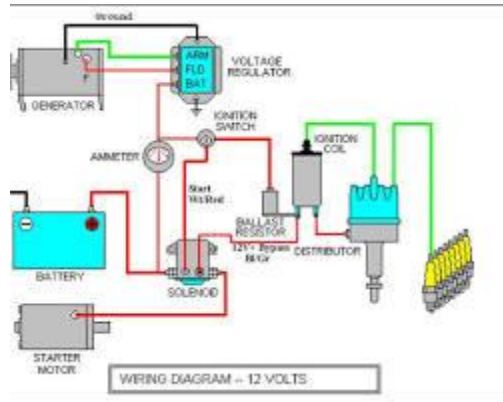

- **Portable electronic devices:**
 - ✓ Cell phones, laptops, and tablets.
- **Renewable Energy systems:**
 - ✓ Solar panels.
 - ✓ Battery storage.

Sub-strand 1.3: Capacitors and Capacitance (8 Lessons)

1.3: Capacitors and Capacitance

a) Principle of Operation of a Capacitor:

- A capacitor stores electrical energy in an electric field between two conductive plates separated by an insulator (dielectric).
- When voltage is applied, charge accumulates on the plates, creating an electric field.
- Capacitance (C) is the ability to store charge, measured in farads (F).

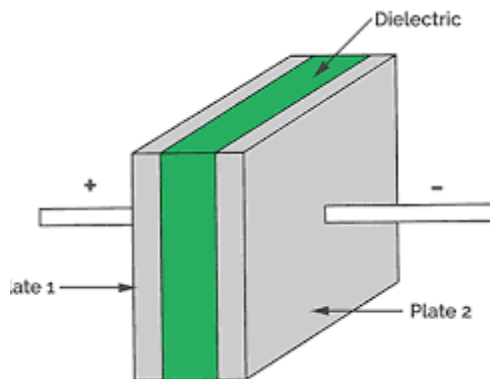

Basic capacitor structure showing plates and dielectric

b) Characteristics of Capacitive Circuits:

- ✓ **Charging and Discharging:** Capacitors charge when connected to a voltage source and discharge when the source is removed.

- ✓ **Voltage-Time Characteristics:** Voltage across a capacitor increases exponentially during charging and decreases exponentially during discharging.
- ✓ **Current-Time Characteristics:** Charging current is high initially and decreases exponentially; discharging current is reversed.
- ✓ **Time Constant (RC):** In an RC circuit, the time constant determines the rate of charging and discharging.

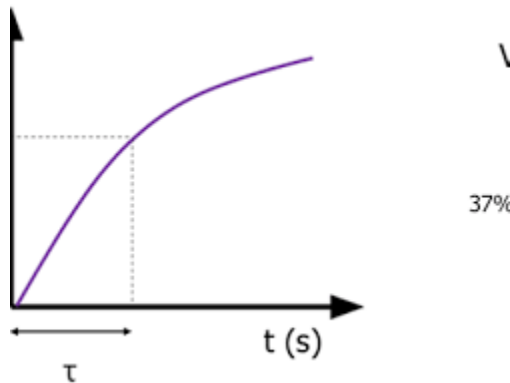

Voltage time graph for a charging capacitor

c) Selecting Appropriate Capacitors:

- **Capacitance Value:** Determined by the application's requirements.
- **Voltage Rating:** Must exceed the maximum voltage in the circuit.
- **Dielectric Type:** Affects capacitance, voltage rating, and temperature stability. (e.g., ceramic, electrolytic, tantalum).
- **Physical Size and Mounting:** Considerations for circuit board layout.
- **Datasheets:** Provide detailed specifications for capacitor selection.

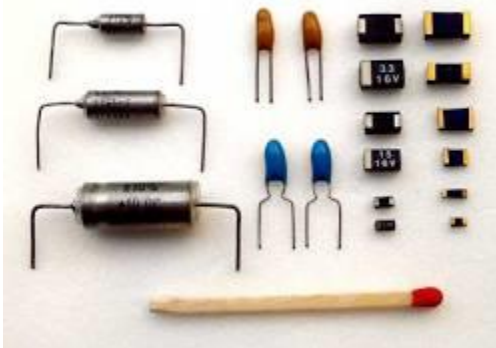

Various types of capacitors (ceramic, electrolytic, tantalum)

d) Series and Parallel Connection of Capacitors:

- **Series Connection:**

- ✓ Total capacitance: $1/C_T = 1/C_1 + 1/C_2 + 1/C_3 + \dots$
- ✓ Total capacitance is less than the smallest individual capacitance.
- ✓ Voltage is divided across capacitors.
- **Parallel Connection:**
 - ✓ Total capacitance: $C_T = C_1 + C_2 + C_3 + \dots$
 - ✓ Total capacitance is the sum of individual capacitances.
 - ✓ Voltage is the same across all capacitors.

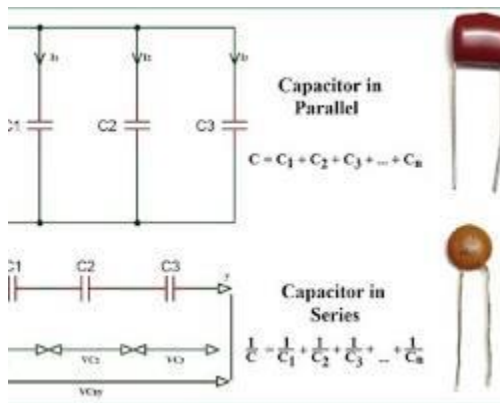

Series capacitor circuit diagram

e) Importance of Capacitors in Electrical Appliances:

- **Charge Storage:** Used in power supplies for smoothing and filtering.
- **Motor Control:** Used for starting and running induction motors.
- **Timer Circuits:** Used in timing applications, such as traffic lights and electronic timers.
- **Filtering:** Used to remove unwanted AC components from DC signals.
- **Coupling and Decoupling:** Used to block DC signals and pass AC signals.



Traffic light circuit board with capacitors

Sub-strand 1.4: Cells and Batteries

a) Principle of Operation of a Simple Cell:

- A simple cell converts chemical energy into electrical energy.
- It consists of two different electrodes (metals) immersed in an electrolyte (solution).
- A chemical reaction between the electrodes and electrolyte produces a voltage.
- Electrons flow from the negative electrode (anode) to the positive electrode (cathode) through an external circuit.

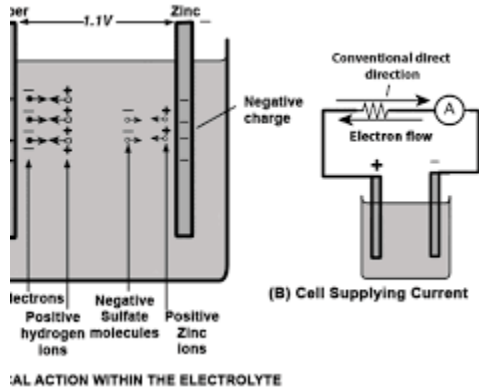

Simple voltaic cell diagram

b) Connecting Series and Parallel Battery Arrays:

- **Series Connection:**
 - ✓ Connecting batteries in series increases the total voltage.
 - ✓ The positive terminal of one battery is connected to the negative terminal of the next.
 - ✓ Total voltage: $V_T = V_1 + V_2 + V_3 + \dots$

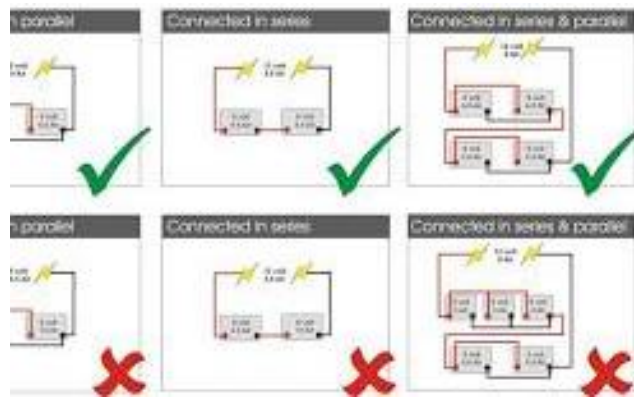

Batteries connected in series

- **Parallel Connection:**
 - ✓ Connecting batteries in parallel increases the total current capacity.
 - ✓ Positive terminals are connected together, and negative terminals are connected together.
 - ✓ Total voltage remains the same.

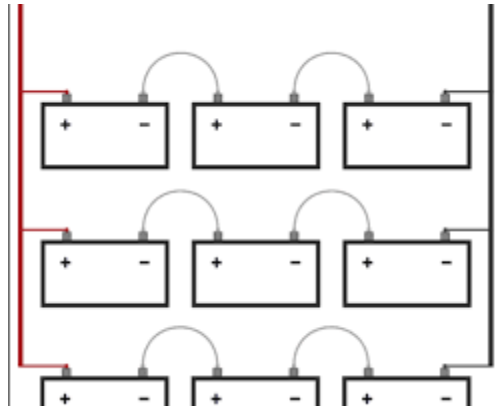

Batteries connected in parallel

c) Battery Charging Procedure for a Secondary Battery:

- Secondary batteries (rechargeable) can be recharged by reversing the chemical reaction.
- A charger provides a reverse current to restore the battery's chemical state.
- Charging rate and voltage must be controlled to prevent damage.
- Proper ventilation is essential during charging.



Battery charger connected to a car battery

d) Maintenance Procedures for Cells and Batteries:

- ✓ **Terminal Cleaning:** Clean corroded terminals to ensure good contact.
- ✓ **Water Level Maintenance:** For lead-acid batteries, maintain the electrolyte level with distilled water.
- ✓ **Proper Storage:** Store batteries in a cool, dry place.
- ✓ **Prevention Against Overcharging and Undercharging:** Use appropriate chargers and avoid deep discharges.



Cleaning battery terminals

e) Importance of Safe Disposal of Cells and Batteries:

- Batteries contain hazardous materials (heavy metals, acids) that can contaminate the environment.
- Recycle batteries through designated collection centers.
- Avoid disposing of batteries in regular trash or burning them.



Battery recycling symbol

STRAND 2.0: ELECTRICAL MACHINES

Sub-strand 2.1: Magnetism

a) Magnetic Properties of Materials:

- ✓ **Ferromagnetic Materials:** Strongly attracted to magnets (iron, nickel, cobalt).



Iron filings attracted to a magnet

- ✓ **Paramagnetic Materials:** Weakly attracted to magnets (aluminum, platinum).
- ✓ **Diamagnetic Materials:** Weakly repelled by magnets (copper, water).
- ✓ **Magnetic Domains:** Microscopic regions within ferromagnetic materials that align to produce magnetism.

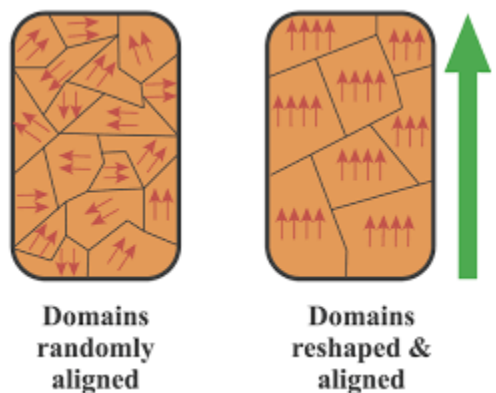

Magnetic domains in a material

b) Magnetization and Demagnetization Procedures:

- **Magnetization:**
 - ✓ Stroking with another magnet.
 - ✓ Placing in a strong magnetic field.
 - ✓ Using an electromagnet.

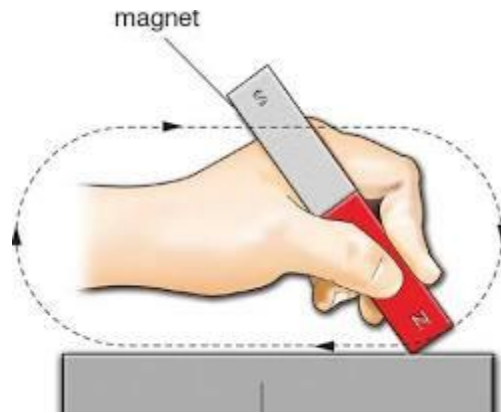

Stroking a metal with a magnet

- **Demagnetization:**
 - ✓ Heating.
 - ✓ Hammering or dropping.
 - ✓ Placing in an alternating magnetic field.

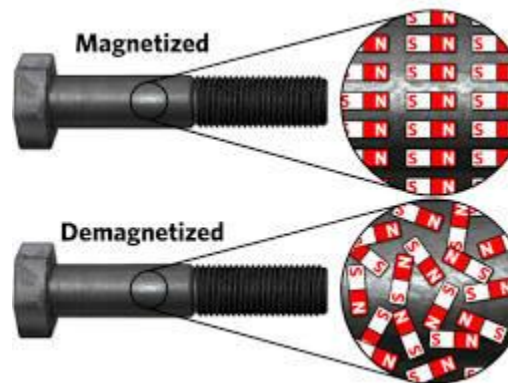

Metal being heated to demagnetize it

c) Magnetic Field Patterns Around a Magnet:

- **Magnetic Field Lines:** Invisible lines that show the direction and strength of a magnetic field.
- **Bar Magnet:** Field lines loop from the north pole to the south pole.

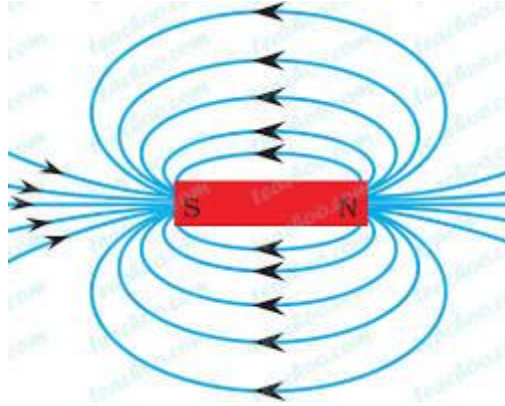

Magnetic field lines around a bar magnet

- **U-Shape Magnet:** Concentrated field between the poles.

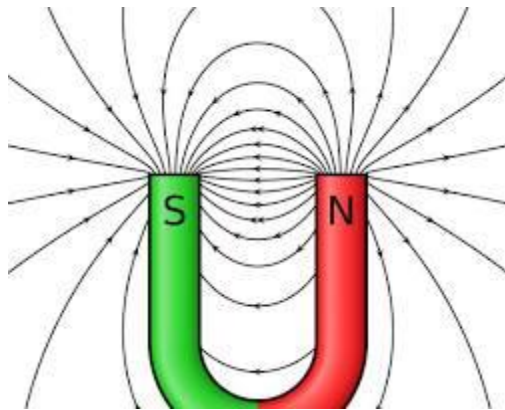

Magnetic field lines around a U-shape magnet

- **Ring or Disc Magnet:** Field lines form closed loops.

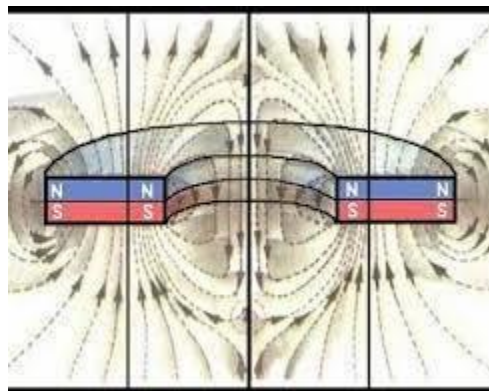

Magnetic field lines around a ring magnet

- **Visualizing Magnetic Fields:** Iron filings, compasses, magnetometers, and Ferro fluids.

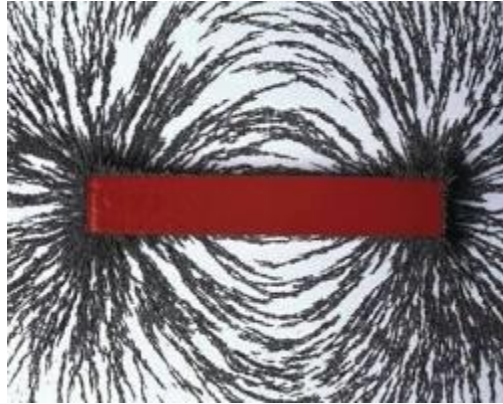

Iron filings showing magnetic field lines

d) Care for Magnets Used in Equipment at a Workplace:

- **Storage:**
 - ✓ Use magnetic keepers to maintain strength.
 - ✓ Store in north-south orientation to prevent demagnetization.

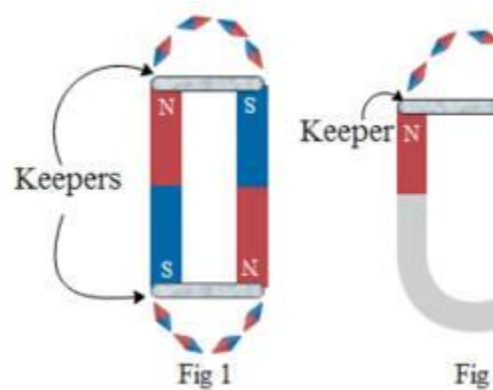

Magnets stored with magnetic keepers

- **Handling:**
 - ✓ Avoid dropping or hitting magnets.
 - ✓ Keep away from high temperatures.
 - ✓ Shield from strong magnetic fields.

e) Application of Magnets in Day-to-Day Life:

- **Electric Motors and Generators:** Convert electrical and mechanical energy.

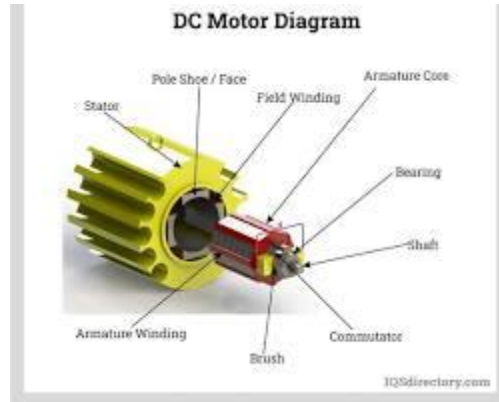

Electric motor

- **Speakers and Microphones:** Convert electrical signals to sound and vice versa.



Speaker showing a magnet

- **Magnetic Storage Devices:** Hard drives, magnetic tapes.



Hard drive showing magnetic platters

- **Magnetic Resonance Imaging (MRI):** Medical imaging.



MRI machine

- **Magnetic Levitation (Maglev) Trains:** High-speed transportation.



Maglev train

- **Compass:** Navigation.



Compass

Sub-strand 2.2: Electromagnetism

a) Principle of Electromagnetism:

- Electromagnetism is the interaction between electricity and magnetism.
- A current-carrying conductor produces a magnetic field.
- A changing magnetic field induces an electric current.

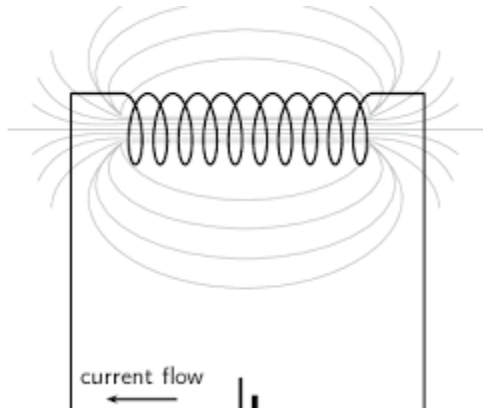

Wire with current flowing, showing the magnetic field around it

b) Magnetic Field Pattern of a Current-Carrying Conductor:

- **Straight Wire:** Magnetic field forms concentric circles around the wire.
 - ✓ Right-hand rule: Thumb points in the direction of current, fingers curl in the direction of the magnetic field.

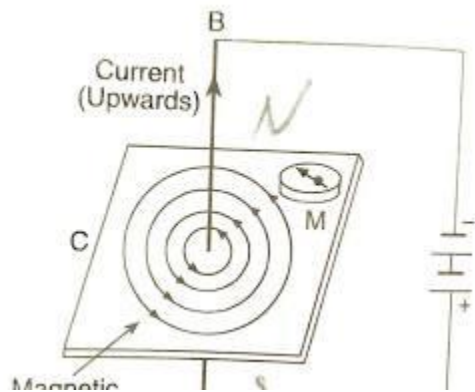

Magnetic field around a straight current carrying wire

- **Coil (Loop):** Magnetic field lines pass through the center of the loop, creating a stronger field.

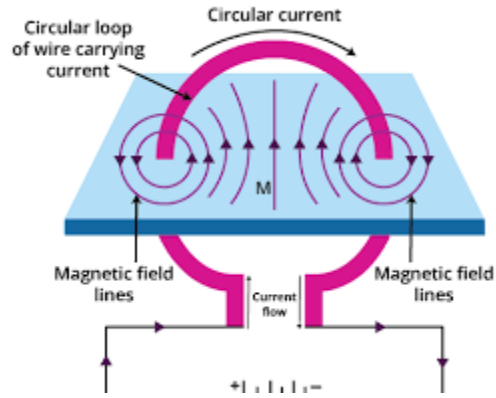

Magnetic field around a current carrying loop

- **Solenoid:** A coil of wire that produces a strong, uniform magnetic field.

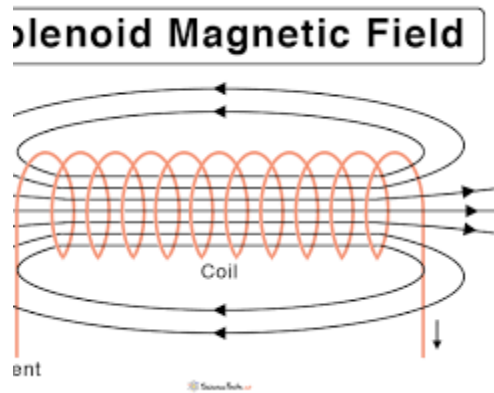

Magnetic field around a solenoid

c) Constructing a Solenoid:

- Parameters affecting solenoid strength:
 - ✓ Number of turns: More turns, stronger field.
 - ✓ Current: More current, stronger field.
 - ✓ Core material: Ferromagnetic core (iron) increases field strength.
 - ✓ Coil length: Shorter length, stronger field.

Question 7

The solenoid in the figure below has N turns of wire wrapped around a core with magnetic permeability μ . The length of the solenoid is l . What are four ways to increase the inductance of this solenoid?

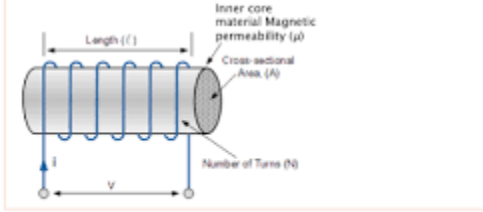

Constructed solenoid with a wire wrapped around a core

d) Constructing Electromagnetic Devices:

- **Electric Bell:** Uses an electromagnet to strike a bell.

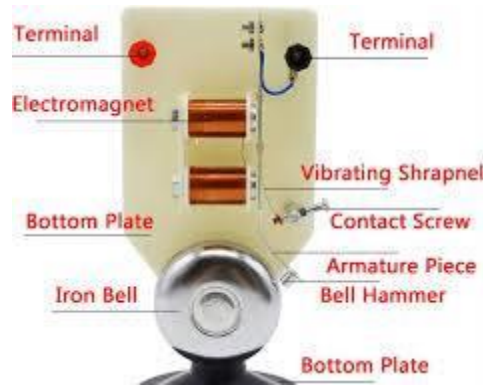

Disassembled electric bell showing the electromagnet

- **Relay:** Electromagnetically controlled switch.

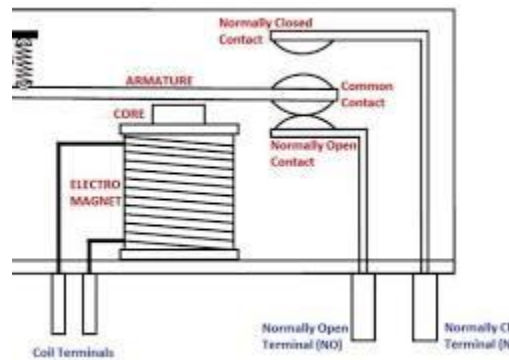

Relay showing the electromagnet and switch contacts

- **Magnetic Pickup:** Used in sensors and audio equipment.



Magnetic pickup from a guitar

e) Troubleshooting Electromagnetic Circuits:

- **Fault Identification:**
 - ✓ Open circuits: Broken wires, faulty connections.
 - ✓ Short circuits: Unintended paths for current.
 - ✓ Loose connections: Poor electrical contact.
- **Troubleshooting Tools:**
 - ✓ Multimeter: Measuring voltage, current, and resistance.
 - ✓ Continuity tester: Checking for breaks in circuits.



Person using a multi-meter to test a circuit

f) Importance of Electromagnetism:

- Electric motors and generators.
- Transformers.
- Electromagnets in industrial applications.
- Magnetic levitation.
- Medical imaging (MRI).

Sub-strand 2.3: Measuring Instruments

a) Principle of Operation of Coil-Based Measuring Instruments:

- These instruments use the interaction between a magnetic field and a current-carrying coil to measure electrical quantities.
- A moving coil galvanometer is a fundamental component.
- When current flows through the coil, it experiences a torque, causing it to rotate.
- The pointer attached to the coil indicates the measured value on a scale.

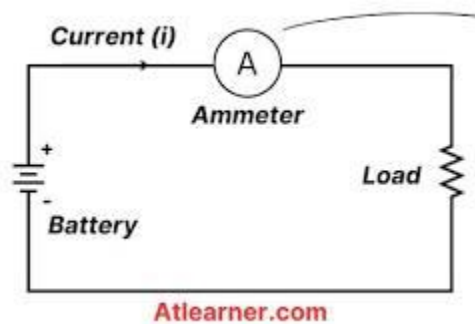

Basic analog ammeter internal structure

b) Computing Resistance Values for ‘Shunts and Multipliers’:

- **Shunts:**
 - ✓ Used to extend the current range of an ammeter.
 - ✓ A low-resistance shunt is connected in parallel with the coil.
 - ✓ The shunt bypasses a portion of the current.

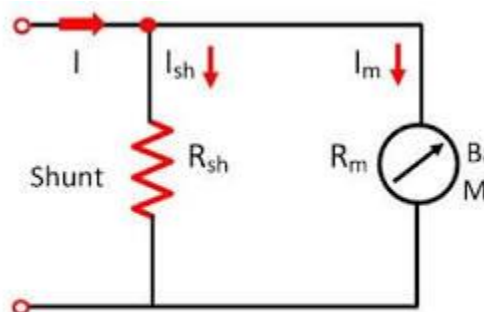

Basic Ammeter Circuit

circuitglobe.com

[Opens in a new window](#) 

Ammeter with a shunt resistor

- **Multipliers:**

- ✓ Used to extend the voltage range of a voltmeter.
- ✓ A high-resistance multiplier is connected in series with the coil.
- ✓ The multiplier drops a portion of the voltage.

measure a maximum potential difference of 4V
with a coil resistance of 3,000 Ω. When a multiplier resistor R_m is
connected in series with the coil, its measuring range
is extended to 12V. Calculate the value of R_m .

$V = IR$

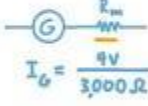
$$I_G = \frac{4V}{3000\Omega}$$
$$R_m = 12,000\Omega - 3,000\Omega$$
$$= 9,000\Omega$$

Voltmeter with a multiplier resistor

- Calculations involve using Ohm's law and circuit analysis to determine the appropriate resistance values.

c) Calibrating Coil-Based Measuring Instruments:

- **Zero Calibration:**

- ✓ Adjusting the pointer to zero when no current or voltage is applied.

- **Fine-Tuning:**

- ✓ Adjusting internal components to improve accuracy.

- **Range Calibration:**

- ✓ Comparing the instrument's readings with a known standard.

- Using calibrated standards to insure accuracy.



Person calibrating an analog multimeter

d) Selecting a Suitable Scale:

- Choosing a scale that provides adequate resolution for the measured quantity.
- Considering the range of expected values.
- Avoiding overloading the instrument.
- Example: using a milliamp scale for measuring small currents, or using a kilo volt scale for measuring high voltages.



Analog multimeter showing different scale selections

e) Importance of Electrical Measuring Instruments:

- Monitoring electrical systems.
- Troubleshooting electrical faults.
- Ensuring accurate measurements in electrical experiments.
- Controlling electrical processes.
- Safety in electrical work.



Various electrical measuring instruments (ammeter, voltmeter, ohmmeter)

STRAND 3.0: ELECTRICAL INSTALLATION

Sub-strand 3.1: Generation, Transmission, and Distribution of Electricity

a) Methods of Generation of Electrical Energy:

- **Thermal Power Plants:** Burn fossil fuels (coal, natural gas) to produce steam, which drives turbines connected to generators.

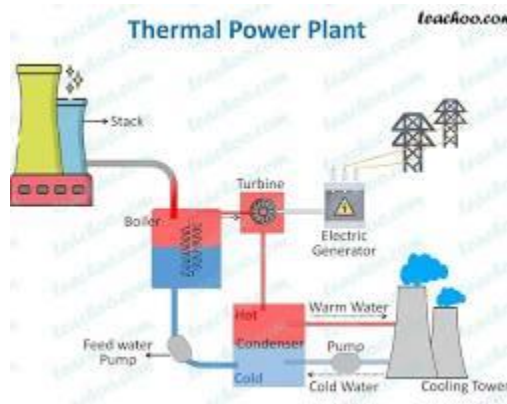

Thermal power plant

- **Hydroelectric Power Plants:** Use the kinetic energy of falling water to drive turbines connected to generators.



Hydroelectric dam

- **Nuclear Power Plants:** Use nuclear fission to generate heat, which produces steam to drive turbines connected to generators.

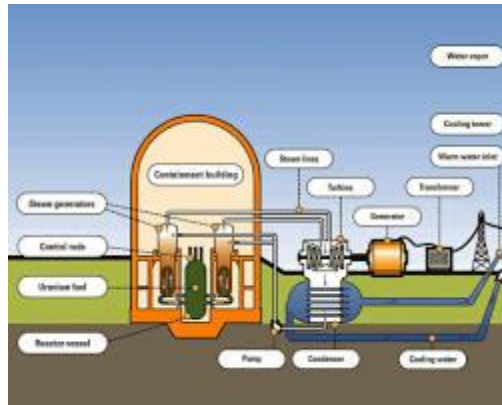

Nuclear power plant

- **Wind Power Plants:** Use wind turbines to convert wind energy into electrical energy.



Wind turbine farm

- **Solar Power Plants:** Use photovoltaic cells to convert sunlight directly into electrical energy.



Solar power plant

- **Geothermal Power Plants:** Use heat from the Earth's interior to produce steam, which drives turbines connected to generators.

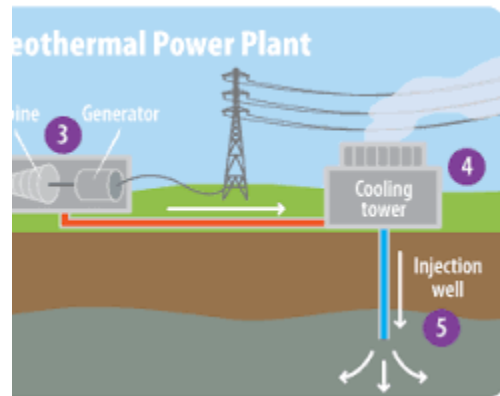

Geothermal power plant

b) Functions of Components in the Electrical Power Transmission Network:

- **Generators:** Convert mechanical energy into electrical energy.



Electrical generator

- **Transformers:** Step up voltage for efficient transmission and step down voltage for distribution.



high voltage transformer

- **Transmission Lines:** Carry high-voltage electricity over long distances.



high voltage transmission towers

- **Substations:** Contain transformers, switchgear, and other equipment for voltage transformation and distribution.



Electrical substation

- **Distribution Lines:** Carry lower-voltage electricity to consumers.

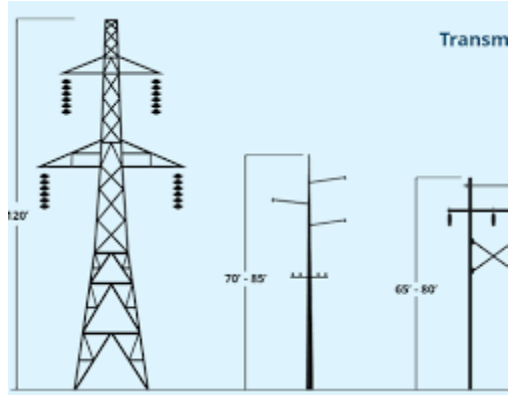

Distribution power lines

- **Circuit Breakers and Switches:** Protect the system from faults and allow for isolation of sections.



Circuit breaker panel

c) 3-Phase 4-Wire Distribution Circuit:

- A 3-phase 4-wire system provides three phase lines and a neutral line.
- Used for distributing power to residential and commercial consumers.
- Phase symmetry ensures balanced loads.
- Line-to-line voltage is higher than line-to-neutral voltage.

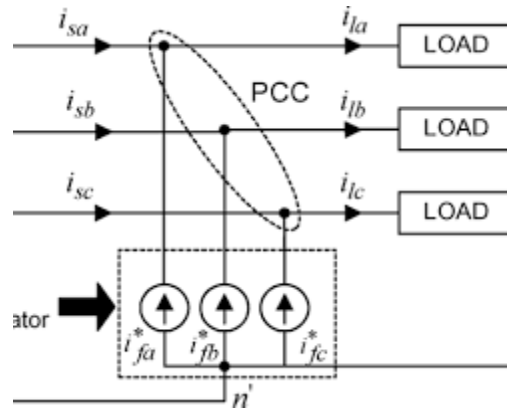

3-phase 4wire distribution diagram

d) Electric Power Grid Network Model:

- A power grid is an interconnected network of generation, transmission, and distribution systems.
- Models can be created using diagrams, simulations, or physical representations.
- Models help visualize the flow of electricity and identify critical components.



simplified power grid diagram

e) Importance of a Grid System:

- Ensures reliable and continuous power supply.
- Allows for efficient distribution of electricity over large areas.
- Enables load balancing and sharing of resources.
- Supports economic development and industrial growth.
- Facilitates the integration of renewable energy sources.



Map showing a countries power grid

Sub-strand 3.2: Equipment at Consumers Intake Point

a) Identifying Equipment at Consumers Electrical Power Intake Point:

- The consumer's intake point is where the electrical supply from the distribution network enters the building.
- Common equipment includes:
 - ✓ Isolation switch (main switch)
 - ✓ Electricity meter
 - ✓ Circuit breakers (main circuit breaker)
 - ✓ Cartridge fuses
 - ✓ Consumer control unit (distribution board/consumer unit)
 - ✓ Earthing terminal



Electrical meter

b) Functions of Control Equipment:

- **Isolation switch (main switch):**
 - ✓ Provides a means to completely disconnect the electrical supply for maintenance or emergencies.



Isolation switch

- **Electricity meter:**
 - ✓ Measures the amount of electrical energy consumed.



Electricity meter

- **Circuit breakers (main circuit breaker):**
 - ✓ Protect the installation from over-currents and short circuits.



Circuit breaker

- **Cartridge fuses:**
 - ✓ Provide backup protection against over-currents.



Cartridge fuse

- **Consumer control unit (distribution board/consumer unit):**
 - ✓ Distributes the electrical supply to individual circuits within the building.
 - ✓ Contains circuit breakers or fuses for each circuit.



Consumer control unit opened

c) Installing Control Equipment in the Correct Sequence:

- ✓ The correct sequence ensures proper protection and operation.
- ✓ Typical sequence:
 - Isolation switch → Electricity meter → Main circuit breaker/fuses → Consumer control unit.

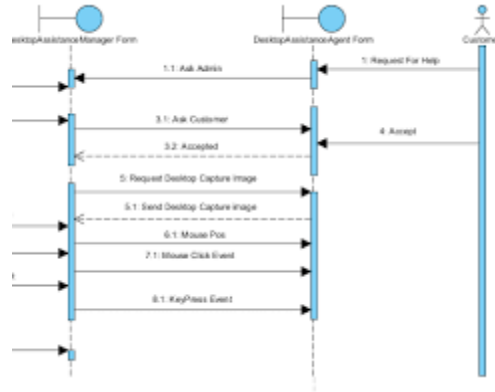
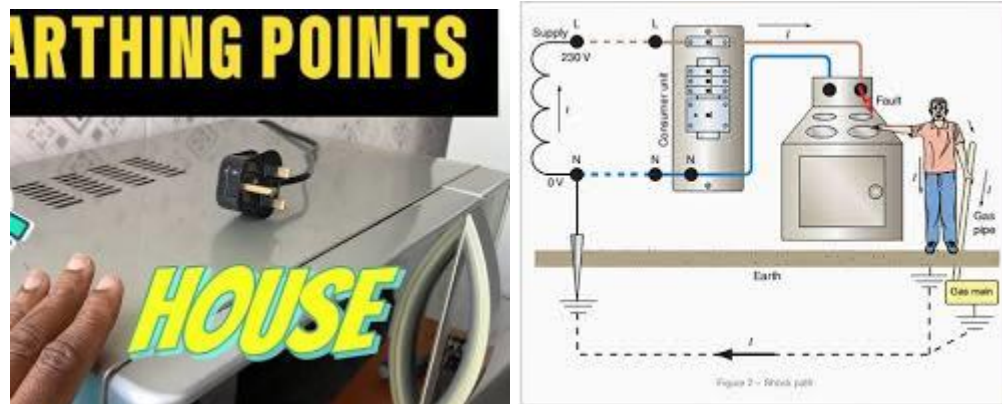

Diagram showing the correct installation sequence

d) Preparing Consumer Earthing Point:

- Earthing provides a safe path for fault currents to flow to the ground.
- Essential for protecting people and equipment from electrical shocks.
- Involves driving an earth electrode into the ground and connecting it to the installation.



Consumer earthing point

e) Importance of Control Equipment:

- Ensures safe and reliable distribution of electrical power.
- Protects against electrical hazards.
- Allows for accurate measurement of energy consumption.
- Facilitates maintenance and troubleshooting.

Sub-strand 3.3: Final Circuits

a) Describing Final Circuits:

- ❖ Final circuits are the circuits that connect the consumer unit to the points of use (lights, sockets, appliances).
- ❖ Types of final circuits:
 - Lighting circuits: Supply power to lighting fixtures.



Installed light fixture

- Power circuits (socket outlets): Supply power to general-purpose sockets.



Installed wall socket

- Cooker circuits: Supply power to electric cookers and ovens.



Installed electrical cooker

- Bell circuits: Supply power to doorbells and signaling systems.



Installed doorbell

- Heating circuits: Supply power to electric heaters and water heaters.



installed water heater

b) Interpreting Electrical Diagrams:

- Electrical diagrams (wiring diagrams, layout diagrams) show the connections between components.
- Established standards (e.g., IEC, BS) define symbols and conventions.
- Ability to interpret diagrams is essential for safe and accurate installation.

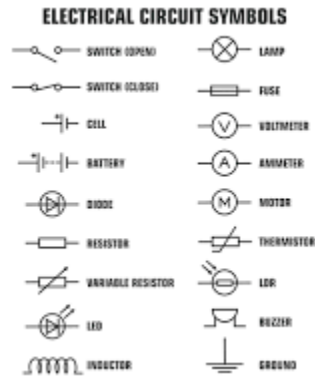

Electrical symbols

c) Preparing a List of Tools and Materials:

- A bill of materials (BOM) lists all the materials required for the installation.
- A tools requisition form lists the necessary tools.
- Examples of tools: wire strippers, screwdrivers, pliers, multimeters.
- Examples of materials: cables, switches, sockets, light fixtures, consumer unit components.



Various electrical installation materials

d) Installing Final Circuits:

- Installation must comply with electrical regulations.
- Proper cable sizing, protection, and earthing are essential.
- Testing after installation ensures safety and functionality.

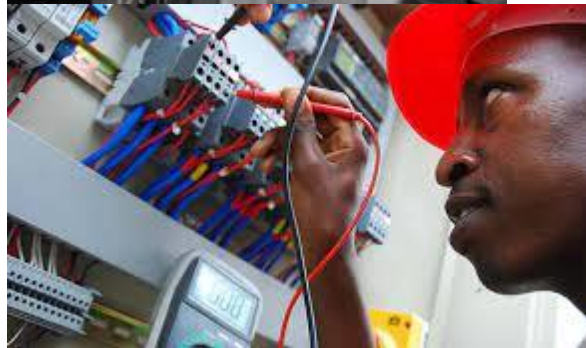

Person testing a electrical circuit

e) Value of Final Circuits:

- Final circuits enable the safe and efficient use of electrical power.
- They provide convenient access to electricity for lighting, appliances, and equipment.
- Properly installed final circuits minimize the risk of electrical hazards.

STRAND 4.0: ELECTRONICS

Sub-strand 4.1: Semiconductor Theory

a) Characteristics of Semiconductor Materials:

- Semiconductors have electrical conductivity between conductors and insulators.
- Common semiconductor materials: silicon (Si) and germanium (Ge).
- Atomic structure: typically have four valence electrons.
- Intrinsic semiconductors: pure semiconductor materials with equal numbers of electrons and holes.
- Extrinsic semiconductors: doped semiconductors with added impurities.
- Conductivity: can be controlled by doping and temperature.



Germanium crystal

b) Doping Process in Semiconductors:

- Doping: adding impurities to intrinsic semiconductors to alter their conductivity.
- N-type semiconductors: doped with pentavalent impurities (e.g., phosphorus) to create excess electrons.

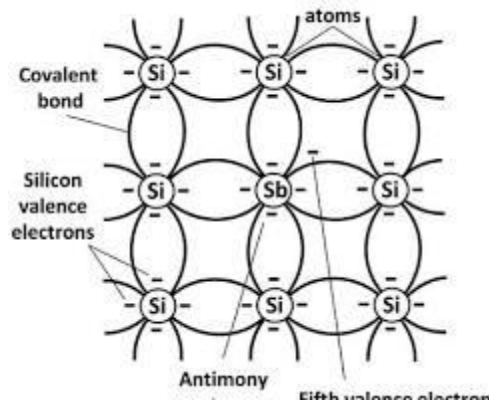

N-type semiconductor doping diagram

- P-type semiconductors: doped with trivalent impurities (e.g., boron) to create excess holes.

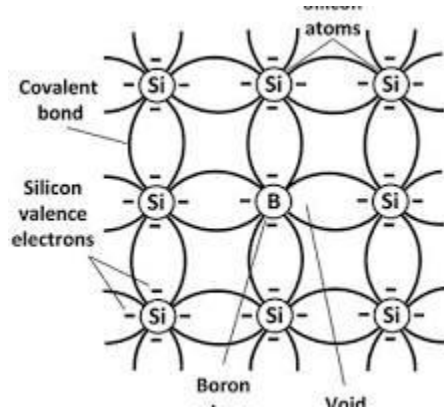

P-type semiconductor doping diagram

- Doping controls the concentration of charge carriers (electrons and holes).

c) Simulating Covalent Bonding in Extrinsic Semiconductors:

- Covalent bonding: sharing of electrons between atoms.
- In extrinsic semiconductors, dopant atoms create excess electrons or holes.
- Role-playing can simulate the movement of electrons and holes.

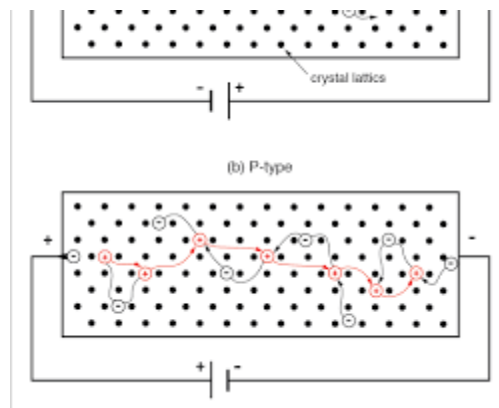

Holes and electrons moving in a semiconductor

d) Formation of a PN Junction:

- PN junction: formed by joining P-type and N-type semiconductors.
- Depletion region: a region at the junction with no free charge carriers.
- Forward bias: voltage applied to reduce the depletion region and allow current flow.

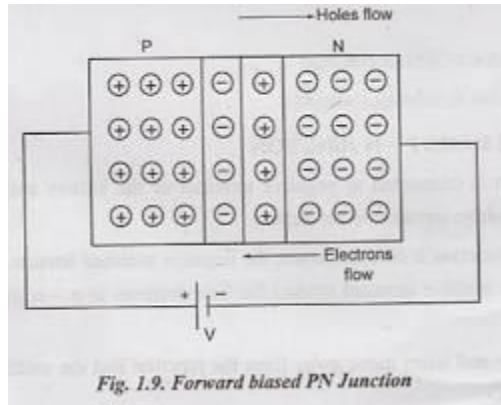

PN junction with forward bias

- Reverse bias: voltage applied to widen the depletion region and block current flow.

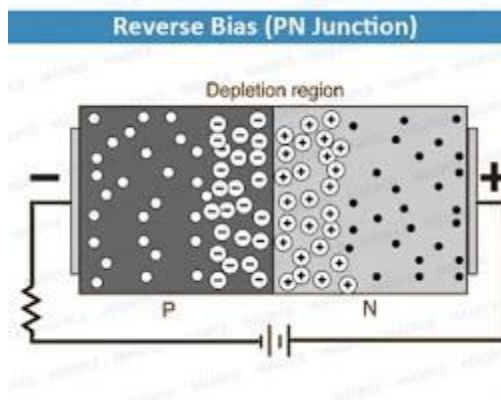

PN junction with reverse bias

e) Importance of Electronic Materials:

- Semiconductors are fundamental to modern electronics.
- Used in transistors, diodes, integrated circuits (ICs), and sensors.
- Enable the development of computers, smartphones, and other electronic devices.

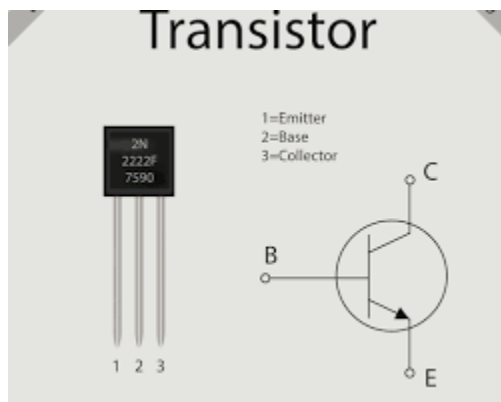

Transistor

Sub-strand 4.2: Semiconductor Diodes

a) Operation of a Semiconductor Diode:

- ✓ A diode is a two-terminal semiconductor device that allows current to flow in one direction only.
- ✓ It consists of a PN junction.
- ✓ **Forward biasing:** Positive terminal connected to P-type, negative to N-type; allows current flow.

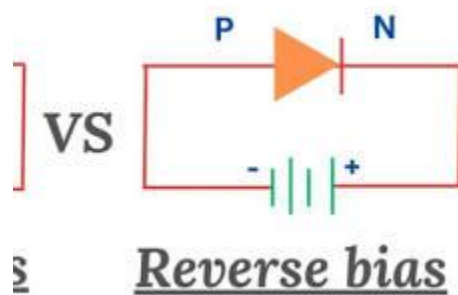

Diode with forward bias

- ✓ **Reverse biasing:** Positive terminal connected to N-type, negative to P-type; blocks current flow.

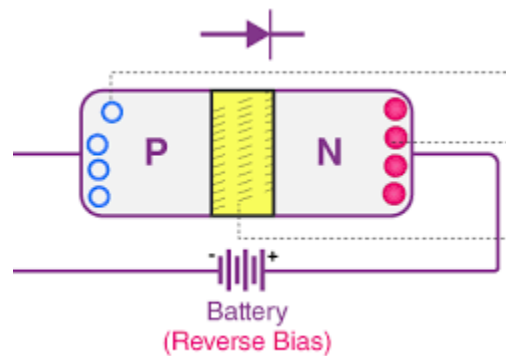

Diode with reverse bias

- ✓ Electron-hole recombination: process of electrons and holes combining in forward bias.

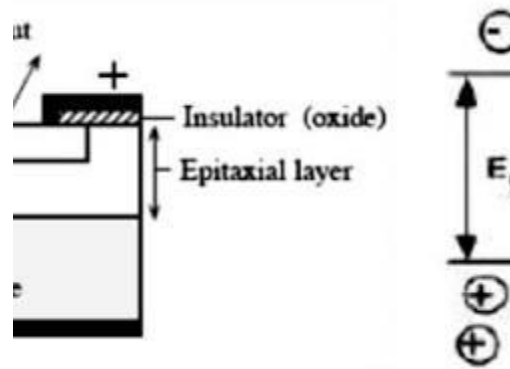

Electron hole recombination in a diode

b) Current-Voltage Characteristics of Diodes:

- **Forward bias:** Current increases exponentially with voltage after a threshold voltage (knee voltage).

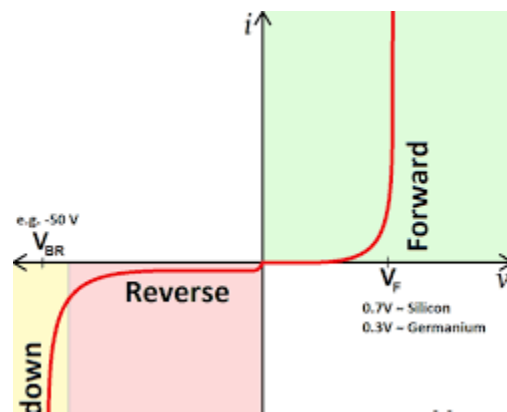

Diode's forward bias IV curve

- **Reverse bias:** Small leakage current flows until breakdown voltage is reached.

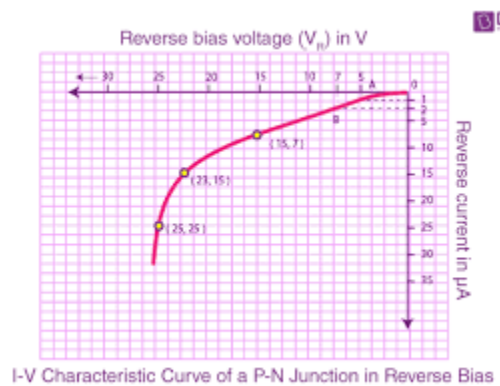

I-V Characteristic Curve of a P-N Junction in Reverse Bias

Diode's reverse bias IV curve

- Experiment using a diode, power supply, voltmeter, and ammeter to verify these characteristics.

c) Constructing Diode Circuits:

- **Rectification:** Converting AC to DC using diodes (half-wave, full-wave).

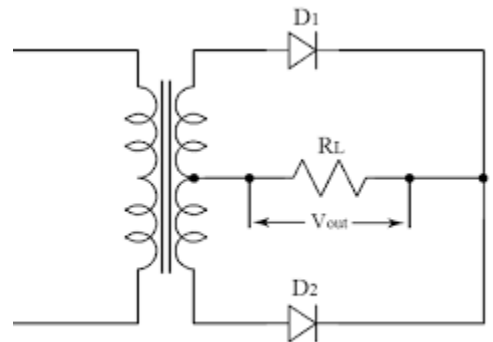

<https://circuitfever.com>

full wave rectifier circuit

- **Regulation:** Maintaining constant voltage using Zener diodes.

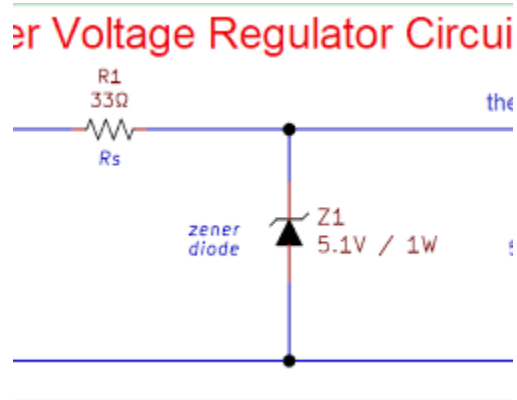

Zener diode voltage regulator circuit

- **Display:** Using LEDs (light-emitting diodes) for indication and lighting.

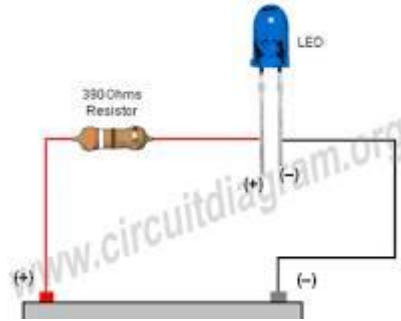

LED circuit

- **Switching:** Using diodes as switches in electronic circuits.

d) Troubleshooting Diode Circuits:

- **Fault identification:**
 - ✓ Short circuit: Diode fails, allowing excessive current.
 - ✓ Open circuit: Diode fails, blocking current flow.
 - ✓ Faulty diodes: Damaged diodes with abnormal characteristics.
- **Troubleshooting tools:**
 - ✓ Multimeter: Checking diode continuity and voltage.
 - ✓ Oscilloscope: Observing diode waveforms.



Multimeter testing a diode

e) Importance of Semiconductor Diodes:

- **LEDs:** Used in lighting, displays, and indicators.

TYPES OF LED

Various LEDs

- **Zener diodes:** Used in voltage regulation and protection.

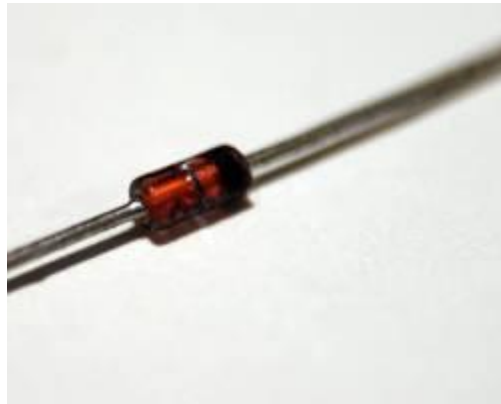

Zener diode

- **Power diodes:** Used in power supplies and rectifiers.

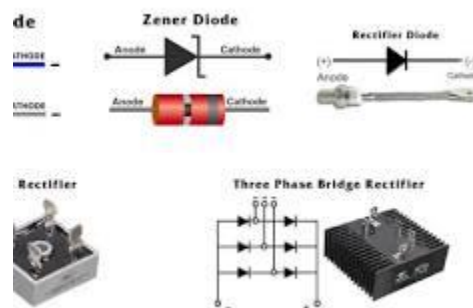

Power diode

- **Infrared diodes:** Used in remote controls and sensors.



Infrared diode

- **Signal diodes:** Used in signal processing and communication.

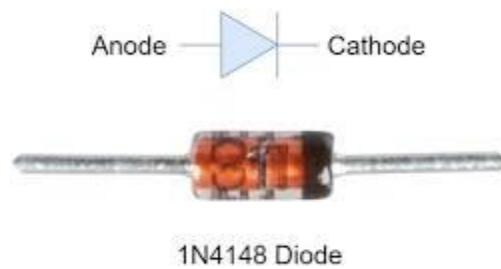

Signal diode

- **Smart traffic lights:** Using LEDs and sensors for efficient traffic control.



Smart traffic lights

- **Pedestrian crossing sensors:** Using infrared diodes for safety.



Pedestrian crossing sensor

Sub-strand 4.3: Transistors

a) Operation of Semiconductor Transistors:

- A transistor is a semiconductor device used to amplify or switch electronic signals.
- Two main types: Bipolar Junction Transistors (BJTs) and Field Effect Transistors (FETs).
- **BJT:** Current-controlled device with three terminals (base, collector, emitter).

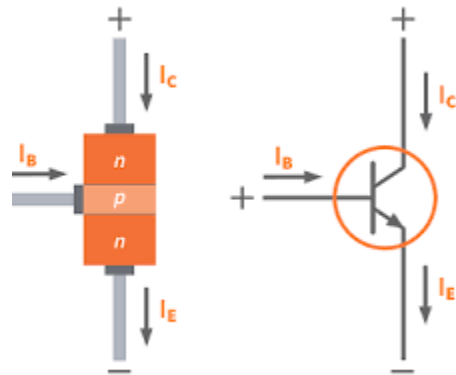

BJT structure diagram

- **FET:** Voltage-controlled device with three terminals (gate, drain, source).

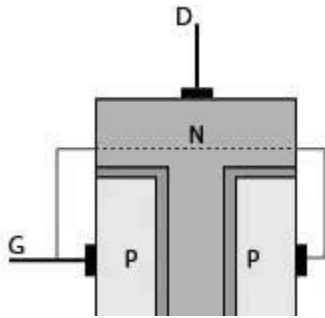

FET structure diagram

- Operation involves controlling current flow between two terminals using the third terminal.

b) Voltage Versus Current Characteristics:

- **BJT characteristics:** Input (base-emitter) and output (collector-emitter) characteristics.

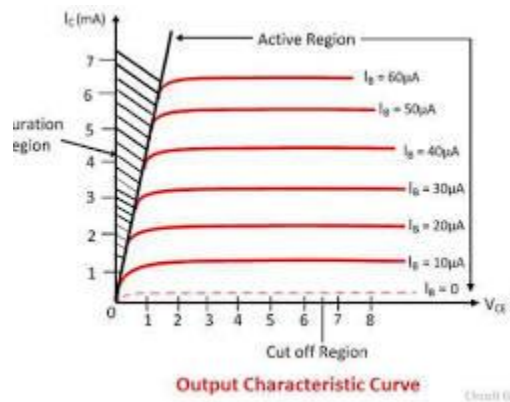

BJT output characteristics graph

- **FET characteristics:** Transfer and output characteristics.

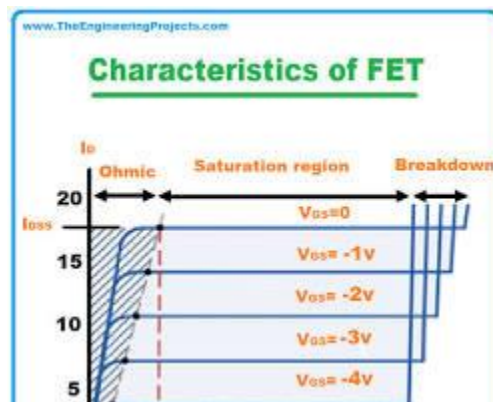

FET output characteristics graph

- Experiment to measure transistor voltage and current and plot the DC characteristics.

c) Selecting an Appropriate Transistor:

- **BJT:** Current gain (h_{FE}), power rating, frequency response, and type (NPN or PNP).
- **FET:** Transconductance (g_m), input impedance, power rating, and type (N-channel or P-channel).
- Application-specific requirements determine the appropriate transistor selection.



Different transistor packages

d) Constructing Transistor Circuits:

- **Switching circuits:** Using transistors to control current flow.

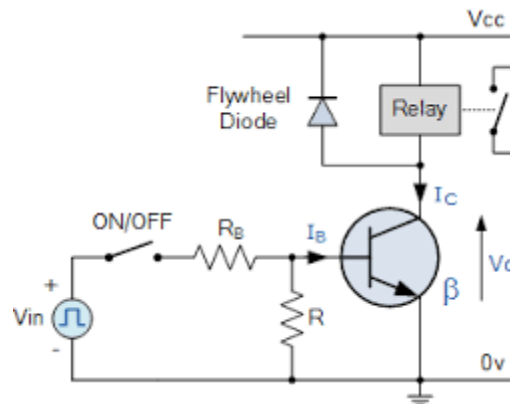

Assembled transistor switching circuit

- **Amplifier circuits:** Using transistors to increase signal strength.

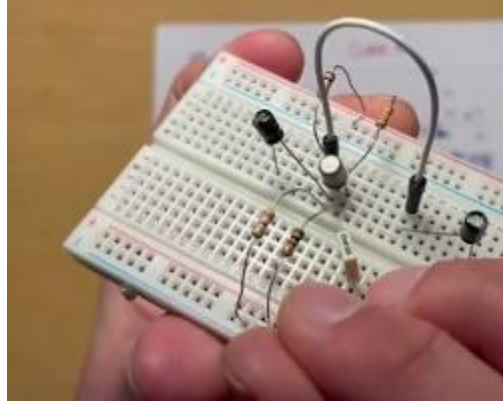

Assembled transistor amplifier circuit

- **Oscillator circuits:** Using transistors to generate periodic signals.

e) Importance of Transistors:

- Fundamental building blocks of modern electronics.
- Used in amplifiers, switches, oscillators, and digital logic circuits.
- Enable the development of computers, smartphones, and other electronic devices.
- Essential in telecommunications, audio systems, and control systems.

Teachers are advised to use course book too.