

COMPETENCY-BASED EDUCATION CBE

KENYA JUNIOR SCHOOL EDUCATION ASSESSMENT

K.J.S.E.A

APRIL HOLIDAY ASSIGNMENT 2026

QUESTION BOOKLET

GRADE 7



THIS BOOKLET CONTAINS ASSIGNMENTS ON:

- ◆ SOCIAL STUDIES
- ◆ PRETECHNICAL STUDIES
- ◆ MANDARIN CHINESE
- ◆ KISWAHILI
- ◆ ISLAMIC RELIGIOUS EDUCATION
- ◆ HINDU RELIGIOUS EDUCATION
- ◆ CHRISTIAN RELIGIOUS EDUCATION
- ◆ INTEGRATED SCIENCE
- ◆ GERMAN
- ◆ ENGLISH
- ◆ FRENCH
- ◆ AGRICULTURE

CREATIVE ARTS AND SPORTS

MATHEMATICS

"Education is the passport to the future, for tomorrow belongs to those who prepare for it today."

AUTHORS: COMPETENCE KENYA EDUCATION GROUP

TABLE OF CONTENT

| LEARNING AREA | PAGE |
|--|------|
| 1. Social Studies | 3 |
| 2. Pre-Technical Studies | 7 |
| 3. Mathematics | 11 |
| 4. Agriculture | 16 |
| 5. Creative Arts and Sports | 20 |
| 6. Christian Religious Education | 23 |
| 7. Hindu Religious Education | 26 |
| 8. French | 29 |
| 9. Mandarin | 32 |
| 10. German | 35 |
| 11. Islamic Religious Education | 38 |
| 12. English | 41 |
| 13. Integrated Science | 47 |
| 14. Kiswahili | 53 |

COMPETENCE BASED EDUCATION

GRADE 7 2026

FORMATIVE ASSESSMENT



NAME: _____ ASSESSMENT NUMBER: _____

SCHOOL: _____ DATE: _____

SOCIAL STUDIES
TIME: 1 HOUR 40 MINUTES

SECTION A: MAP WORK

KERIO AREA

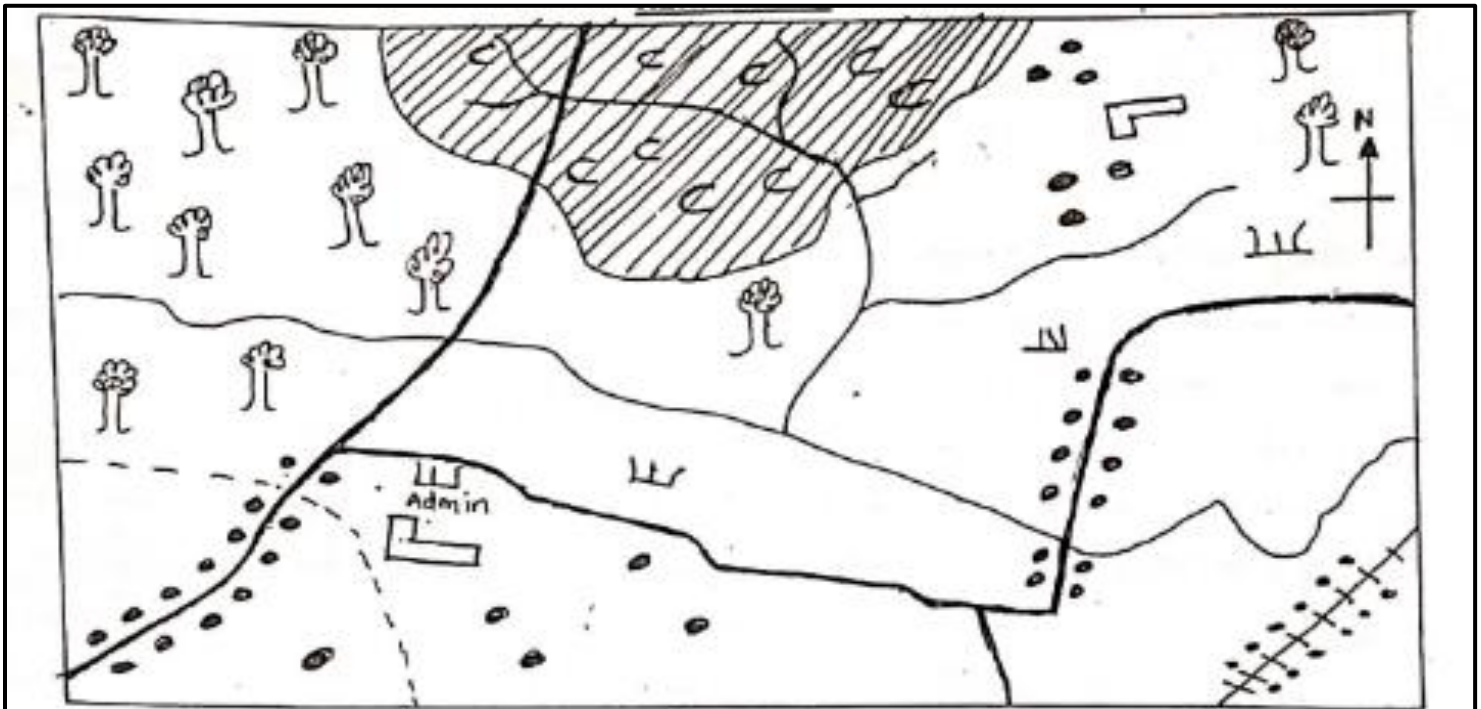

| | | | | |
|------------|--------------|-------------|----------------------------|-----------------------|
| Roads | Forest | River | Settlement | Coffee plantation |
| Shrubs | Boundary | Railway | Administrative centres | |

1. Study the map of Kerio area above and answer the questions.

a) Mention **three features** that make this map a good map (3 marks)

i) _____

ii) _____

iii) _____

b) State **two economic activities** in Kerio area (2 marks)

i) _____

ii) _____

2. Define the term Social Studies. (2 marks)

Branches of Social Studies are three. Name them. (3 marks)

i) _____

ii) _____

iii) _____

3. State **three importances** of studying Social Studies. (3 marks)

i) _____

ii) _____

iii) _____

4. State **four entrepreneurial opportunities** related to Social Studies. (4 marks)

i) _____

ii) _____

iii) _____

iv) _____

5. List **five careers** related to Social Studies. (5 marks)

i) _____

ii) _____

iii) _____

iv) _____

v) _____

7. What is **self-exploration**? (2 marks)

8. State **three theories** that explain the origin of mankind. (3 marks)

- i) _____
- ii) _____
- iii) _____

9. Identify **five factors** that led to the growth of ancient Egyptian civilization. (5 marks)

- i) _____
- ii) _____
- iii) _____
- iv) _____
- v) _____

10. State **four strategies** of addressing gender stereotypes in career choice. (4 marks)

- i) _____
- ii) _____
- iii) _____
- iv) _____

11. a) Define the term **emotions**. (1 mark)

b) State **five types of emotions**. (5 marks)

- i) _____
- ii) _____
- iii) _____
- iv) _____
- v) _____

12. Highlight **five contributions** of early civilizations to the modern world. (5 marks)

- i) _____
- ii) _____
- iii) _____
- iv) _____
- v) _____

13. State **two forms of slavery**. (2 marks)

- i) _____
- ii) _____

14. Explain **three factors** that led to the development of the Indian Ocean slave trade in the 15th century. (3 marks)

- i) _____
- ii) _____
- iii) _____

15. Name **three countries** found in East Africa. (3 marks)

- i) _____
- ii) _____
- iii) _____

COMPETENCE BASED EDUCATION

GRADE 7 2026

FORMATIVE ASSESSMENT



NAME: _____ ASSESSMENT NUMBER: _____

SCHOOL: _____ DATE: _____

PRE-TECHNICAL STUDIES

TIME: 1 HOUR 40 MINUTES

SECTION A: MULTIPLE CHOICE QUESTIONS

Instructions: Choose the correct answer and write the letter in the space provided.

1. Which one of the following is **not** a component of Pre-Technical Studies?
 - A. Computer Science
 - B. Business Studies
 - C. Safety in Work
 - D. Pre-Technical Studies
2. Grade Seven learners were asked to name physical threats to digital devices. Identify one threat from the list below.
 - A. Data theft
 - B. Hard drive damage
 - C. Ransomware
 - D. Virus attack
3. Korir, a Grade 7 learner, visited a farm and saw a farmer spraying chemicals. Which of the following is **not** safety gear the farmer would wear?
 - A. Gloves
 - B. Gumboots
 - C. Safety belt
 - D. Face mask
4. Which one of the following is a hybrid computer?
 - A. Speedometer
 - B. Voltmeter
 - C. Mercury thermometer
 - D. ATM machine
5. A computer is an electronic device that processes data into information. Examples include notebook, laptop, tablet, iPad, and MacBook. Name the computer drawn below.
 - A. Notebook
 - B. Desktop
 - C. iPad
 - D. MacBook
6. Mary wants to send a message to a friend abroad using an ICT tool. Which of the following is **not** an ICT tool she can use?
 - A. Newspaper
 - B. Email
 - C. Video and web conferencing
 - D. Social media

7. Grade Seven learners discussed the differences between technical drawing and artistic drawing. Which group gave the **wrong** answer?
- A. Brian**
 Technical drawing is used to give accurate measurements to scale.
 Artistic drawing is used to express ideas and feelings.
- B. Amina**
 Technical drawing must be precise and interpreted the same way worldwide.
 Artistic drawing does not follow strict rules of dimensioning.
- C. Kevin**
 Technical drawing is done for decoration and personal expression.
 Artistic drawing must follow exact measurements and fixed dimensions.
- D. Faith**
 Technical drawing follows rules and standards.
 Artistic drawing allows personal interpretation by the viewer.
8. Which of the following basic symbols is correctly matched with its meaning?
- A. Centre line
- B. Horizontal line **CL**
- C. Radius **R**
- D. Square **NTS**
9. Which one of the following is **not** an activity learned under Business Studies?
- A. Manipulation
- B. Consumption
- C. Distribution
- D. Production
10. A hazard is anything that has the potential to cause harm, death, or damage to property. Which group consists of hazards only?
- A. Sharp-edged tools, coated electrical wires, slippery floor
- B. Improperly stored drugs and chemicals, falling objects, poorly lit room
- C. Leaking gas, unattended burning candle, working with protective gear
- D. Scattered objects, open wells, well-ventilated room

SECTION B: SHORT ANSWERS

11. Define the following concepts (3 marks):

i) Computer: _____

ii) Data: _____

iii) Information: _____

12. State and explain six characteristics of computers (6 marks)

i) _____

ii) _____

iii) _____

iv) _____

v) _____

vi) _____

13. How would you ensure that your personal and sensitive data is safe online? (4 marks)

i) _____

ii) _____

iii) _____

iv) _____

14. Safety is a situation where one avoids harm, discomfort, or sickness. Highlight four importance of observing safety in a work environment (4 marks)

i) _____

ii) _____

iii) _____

iv) _____

15. Draw and label three types of lines used in technical drawing (6 marks)

i) _____

ii) _____

iii) _____

16. Name four careers related to technical drawing (4 marks)

- i) _____
- ii) _____
- iii) _____
- iv) _____

17. Dimensioning is the process of adding size information to a drawing. State three types of dimensioning (3 marks)

- i) _____
- ii) _____
- iii) _____

COMPETENCE BASED EDUCATION

GRADE 7 2026

FORMATIVE ASSESSMENT



NAME: _____ ASSESSMENT NUMBER: _____

SCHOOL: _____ DATE: _____

MATHEMATICS

TIME: 1 HOUR 40 MINUTES

QUESTIONS

1. Draw an abacus. Use it to determine the **place value of each digit** in the number 451,362,803. (2 marks)

2. Write the number **212,755,124** in words. (2 marks)

3. A company paid **19,698,349** in tax. Round this amount to the **nearest ten million**. (2 marks)

4. Find the **sum of all prime numbers** between 1 and 20. (3 marks)

5. Work out: $85 \times 120 + 40 + 3585 \times 120 + 40 + 35$ (3 marks)

6. Find the **least number** that should be added to 89,534 to make it divisible by 11. (3 marks)

7. Express **1024** as a **product of its prime factors**. (3 marks)

8. Find the **least capacity** of a tank that can fill containers of 12 litres, 36 litres, and 48 litres **without remainder**. (3 marks)

9. Arrange the following fractions in **descending order**: $\frac{2}{3}, \frac{2}{5}, \frac{3}{4}, \frac{1}{2}$ (3 marks)

10. Work out: $\frac{7}{12} - 4\frac{2}{3} - 43$ (2 marks)

11. Find the next **two numbers** in the sequence: (2 marks)

$\frac{1}{7}, \frac{1}{11}, \frac{1}{13}, \frac{1}{17}, \frac{1}{19},$ _____, _____

11. Find the **area** of the rectangle below: (3 marks)

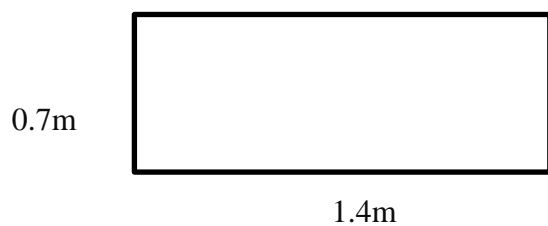

13. What is the **total value of digits** in the number 182.6489? (1 mark)

14. A rectangle has an **area of 400 cm²**. Find the **side of a square** with the same area. (3 marks)

15. What is the **reciprocal** of $3\frac{2}{3}$? (2 marks)

16. Find the **circumference** of the circle below. Take $\pi = \frac{22}{7}$. (3 marks)

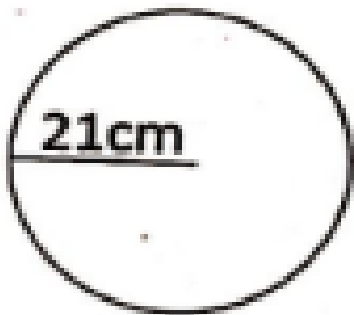

17. Find the **area of the shaded part** in the figure below. (4 marks)

22cm

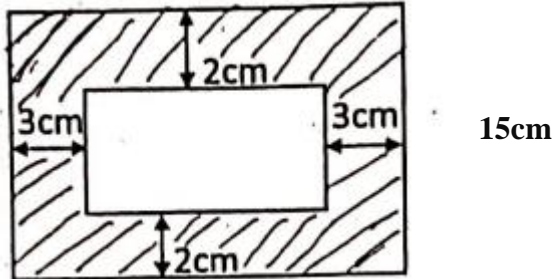

18. Calculate 39 divided by $4\frac{2}{9}$. (2 marks)

19. Find the **square** of 2.7. (2 marks)

20. Mrs. Kemunto spent $\frac{1}{10}$ of her salary on rent, $\frac{2}{5}$ on food, $\frac{3}{10}$ on transport, and saved $\frac{1}{5}$ of the salary the rest. Arrange these **fractions in ascending order**. (3 marks)

COMPETENCE BASED EDUCATION

GRADE 7 2026

FORMATIVE ASSESSMENT



NAME: _____ **ASSESSMENT NUMBER:** _____

SCHOOL: _____ **DATE:** _____

AGRICULTURE

TIME: 1 HOUR 40 MINUTES

1. Define the term soil pollution (2mks)

2. Identify any two ways of water conservation for household gardening (2mks)

i. _____

ii. _____

3. List three types of seedbed that conserve soil moisture (3mks)

i. _____

ii. _____

iii. _____

4. Grade 7 learner wanted to carry out civil education on causes of soil pollution to the neighboring community. List down any three causes of soil pollution they included during practice (3mks)

i. _____

ii. _____

iii. _____

5. Grade 7 learners in Mwingi Junior School were asked by their agriculture teacher to bring some planting seeds. Identify areas where the learners obtained the seeds (2mks)

i. _____

ii. _____

6. Draw a diagram showing drip irrigation method (2mks)

7. List down damages caused by surface runoff (2mks)

- i. _____
 ii. _____

8. A) State two importance of preserving fruits and vegetables (2mks)

- i. _____
 ii. _____

B) State and explain two ways of conserving vitamin and minerals salt in vegetables during food handling, preparation and cooking (4mks)

- i. _____
 ii. _____

9. Identify the practice below as carried out in agriculture (1mk)

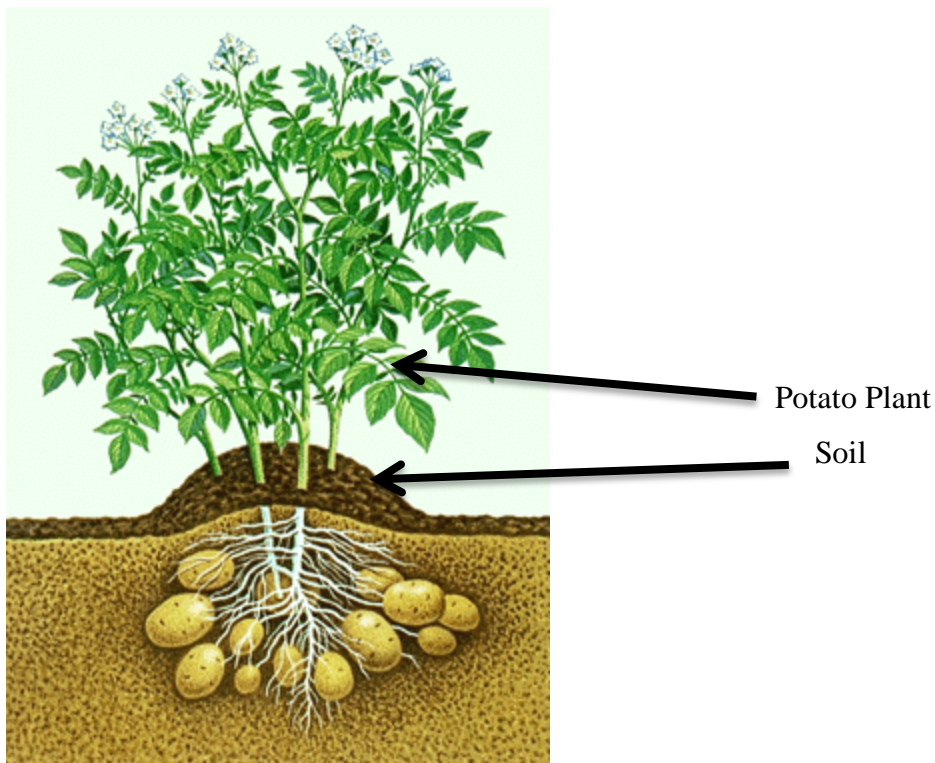

10. Identify two methods of preserving pulses (2mks)

- i. _____
 ii. _____

11. State and explain two nursery management practices done in a tree nursery (4mks)

- i. _____
 ii. _____

12. Outline factors to consider when sorting and grading eggs (3mks)

- i. _____.
- ii. _____.
- iii. _____.

13. List four physical methods of removing weeds (4mks)

- i. _____.
- ii. _____.
- iii. _____.
- iv. _____.

14. How many times should one re-heat preserved food? Explain why (2mks)

15. Differentiate between the following terms (4mks)

i. Afforestation

ii. Deforestation

16. A Grade 7 learner was constructing some water retention structures back at home. Outline two safety measures he should observe when carrying out the practice (2mks)

- i. _____.
- ii. _____.

17. Define the term agroforestry (2mks)

18. Name two examples of vegetative materials (2mks)

- i. _____.
- ii. _____.

19. State two importance of processing raw honey (2mks)

- i. _____.
- ii. _____.

20. Outline two importance of studying agriculture and nutrition (2mks)

- i. _____.
- ii. _____.

COMPETENCE BASED EDUCATION

GRADE 7 2026

FORMATIVE ASSESSMENT



NAME: _____ **ASSESSMENT NUMBER:** _____

SCHOOL: _____ **DATE:** _____

CREATIVE ARTS AND SPORTS

TIME: 1 HOUR 40 MINUTES

1. Define the following terms:

i. Sports (1mk)

ii. Creative arts (1mk)

2. What are the importance of learning creative arts and sports in our society? (5mks)

i. _____

ii. _____

iii. _____

iv. _____

v. _____

3. State 4 components of Creative Arts and Sports (4mks)

i. _____

ii. _____

iii. _____

iv. _____

4. List four elements of a dance (4mks)

i. _____

ii. _____

iii. _____

iv. _____

5. Differentiate between primary and secondary colours (2mks)

i. Primary colours

ii. Secondary colours

6. State and explain two principles of visual arts (4mks)

i. _____

ii. _____





7. Name any 3 career pathways in creative arts and sports (3mks)

i. _____

ii. _____

iii. _____

8. Name the following notes and draw their corresponding rests (8mks)

| Note Name | Symbol | Rest Symbol |
|---|--------|-------------|
|  | | |
|  | | |
|  | | |
|  | | |

9. List techniques used while finishing a race in athletics (3mks)

- i. _____.
- ii. _____.
- iii. _____.

10. State 3 examples of short races (3mks)

- i. _____.
- ii. _____.
- iii. _____.

11. Write 3 techniques used in long jump (3mks)

- i. _____.
- ii. _____.
- iii. _____.

12. Draw and label a long jump pitch (5mks)

13. Describe how to perform a chest pass in Netball (5mks)

- a. _____.
- b. _____.
- c. _____.
- d. _____.
- e. _____.

14. Define the following terms in music (2mks)

- a) Tempo _____.
- b) Pitch _____.

COMPETENCE BASED EDUCATION

GRADE 7 2026

FORMATIVE ASSESSMENT



NAME: _____ ASSESSMENT NUMBER: _____

SCHOOL: _____ DATE: _____

CHRISTIAN RELIGIOUS EDUCATION

TIME: 1 HOUR 40 MINUTES

1. During a C.R.E lesson, Grade 7 learners discussed the importance of learning Christian Religious Education. **Write five importance** they recorded in their exercise books. (5 marks)

- a. _____
- b. _____
- c. _____
- d. _____
- e. _____

2. After learning about the **first and second accounts of creation**, learners discussed the differences between the two accounts. **Write four differences** they discussed. (4 marks)

| First creation account | Second creation account |
|------------------------|-------------------------|
| | |
| | |
| | |
| | |

3. From the Biblical account of creation, **write three attributes of God**. (3 marks)

- a. _____
- b. _____
- c. _____

4. **Write four ways** in which human beings can protect and care for animals, fish, and birds. (4 marks)

- a. _____
- b. _____
- c. _____
- d. _____

5. **Write two ways** in which human beings misuse natural resources. (2 marks)

- a. _____
- b. _____

6. Grade 7 learners stated some natural resources found in our environment. **Name three natural resources** they mentioned. (3 marks)

- a. _____
- b. _____
- c. _____

7. **Name the law books found in the Bible.** (5 marks)

- a. _____
- b. _____
- c. _____
- d. _____
- e. _____

8. **Give five importance of the Bible** in society today. (5 marks)

- a. _____
- b. _____
- c. _____
- d. _____
- e. _____

9. **State and explain three roles of the Bible** in holistic growth. (6 marks)

10. **Describe the second account of creation** according to Genesis 2:16–25. (6 marks)

- a. _____
- b. _____
- c. _____
- d. _____
- e. _____
- f. _____

11. **How does God reveal Himself** to Christians today? (3 marks)

- a. _____
- b. _____
- c. _____

COMPETENCE BASED EDUCATION

GRADE 7 2026

FORMATIVE ASSESSMENT



NAME: _____ ASSESSMENT NUMBER: _____

SCHOOL: _____ DATE: _____

HINDU RELIGIOUS EDUCATION

TIME: 1 HOUR 40 MINUTES

Answer all questions in the spaces provided

1. Define the term **Paramatma**. (3 marks)

2. State three qualities of an Enlightened Being. (3 marks)

i) _____

ii) _____

iii) _____

3. Name three Enlightened Beings studied in Grade 7 HRE. (3 marks)

i) _____

ii) _____

iii) _____

4. Outline three ways Lord Krishna demonstrated divine protection. (3 marks)

i) _____

ii) _____

iii) _____

5. State three teachings of Lord Buddha about dukkha (suffering). (3 marks)

i) _____

ii) _____

iii) _____

6. Define the Jain principle of Ahimsa. (3 marks)

7. Outline three benefits of practicing Ahimsa in society. (3 marks)

- i) _____.
- ii) _____.
- iii) _____.

8. Name four scriptures studied in Grade 7 HRE. (4 marks)

- i) _____
- ii) _____
- iii) _____
- iv) _____

9. State three key messages of the Shanti Mantra in the Yajur Veda. (3 marks)

- i) _____.
- ii) _____.
- iii) _____.

10. Define the term Dharma. (3 marks)

11. Outline three ways Dharma promotes peaceful coexistence. (3 marks)

- i) _____.
- ii) _____.
- iii) _____.

12. State three teachings found in the Sukhmani Sahib. (3 marks)

- i) _____.
- ii) _____.
- iii) _____.

13. Name three Jain principles taught in HRE. (3 marks)

- i) _____.
- ii) _____.
- iii) _____.

14. Define Purusharth. (3 marks)

15. State three benefits of practicing Purusharth in school life. (3 marks)

- i) _____.
- ii) _____.
- iii) _____.

16. Define Daya in Sikh Dharma. (3 marks)

17. Define Nimrata. (3 marks)

18. Outline three ways Dara Shikoh promoted religious harmony. (3 marks)

- i) _____.
- ii) _____.
- iii) _____.

19. State three ways scriptures guide ethical conduct in daily life. (3 marks)

- i) _____.
- ii) _____.
- iii) _____.

20. Outline three outcomes of promoting peace through religious teachings. (3 marks)

- i) _____.
- ii) _____.
- iii) _____.

COMPETENCE BASED EDUCATION

GRADE 7 2026

FORMATIVE ASSESSMENT



NAME: _____ ASSESSMENT NUMBER: _____

SCHOOL: _____ DATE: _____

FRENCH

TIME: 1 HOUR 40 MINUTES

1. Read the passage and answer the questions. (5 marks)

Mary est étudiante. Elle est en classe sixième. Thomas aussi est étudiant. Il est en classe huitième. Ils vont à l'école Heshima Académie. Mary a treize ans et Thomas a quatorze ans.

a) Qui est la fille dans le passage ?

b) Qui est le garçon dans le passage ?

c) Comment s'appelle l'école de Mary et Thomas ?

d) Write in figures:

Quatre-vingts _____

Cent _____

Soixante-trois _____

e) Write in French:

112 _____

2025 _____

518 _____

2. Use the correct form of the verbs (être, avoir, parler) to complete the sentences.

Use: (est, parle, as, suis, avons) (5 marks)

- a) Je _____ étudiant.
- b) Elle _____ ma sœur.
- c) Tu _____ dix chaises.
- d) Nous _____ trois stylos.
- e) David _____ swahili et anglais.

3. Arrange the words below to form correct sentences. (5 marks)

a) habite / Kitengela / à / j'

b) quinze / j' / ans / ai

c) Jane / s'appelle / elle

d) poisson / mange / je

e) école / va / à / il / l'

4. Quelle heure est-il ? Write the time in words. (4 marks)

12h06 _____

8h30 _____

5h25 _____

09h05 _____

5. Write a composition about yourself in French. (10 marks)

COMPETENCE BASED EDUCATION

GRADE 7 2026

FORMATIVE ASSESSMENT



NAME: _____ ASSESSMENT NUMBER: _____

SCHOOL: _____ DATE: _____

MANDARIN CHINESE
TIME: 1 HOUR 40 MINUTES

Grammar & Vocabulary (15 Marks)

1. Write the correct response to the question

Qǐ xiě chū “Nǐ jiào shénme míngzi?” de huídá. (3 marks)

2. Write in pinyin:

“Wǒ shísān suì.” (3 marks)

3. Arrange the words to form a correct sentence. (3 marks)

wǒ / zhù / zài / Nàiluóbì

4. Write three occupations.

Xiě chū sān gè zhíyè yòng pīn yīn. (3 marks)

i. _____

ii. _____

iii. _____

5. Change the sentence into a negative form. (3 marks)

Wǒ xǐhuān tīng yīnyuè.

任务二: Reading Comprehension (15 Marks)

Read the passage and answer the questions.

Wǒ jiā yǒu sì kǒu rén: bàba, māma, wǒ hé mèimei.

Bàba shì yīshēng, māma shì lǎoshī.

Wǒ zhōumò xǐhuān kàn shū.

6. How many people are there in my family?

Wǒ jiā yǒu jǐ kǒu rén? (3 marks)

7. What is father's job?

Bàba zuò shénme gōngzuò? (3 marks)

8. What do I like to do on weekends?

Zhōumò wǒ xǐhuān zuò shénme? (3 marks)

9. Write two family members in pinyin.

Xiě chū liǎng gè jiātíng chéngyuán yòng pīn yīn. (3 marks)

i. _____

ii. _____

10. Retell the passage in your own words.

Yòng zìjǐ de huà fùshù duǎnwén. (3 marks)

Writing (20 Marks)**Choose ONE topic.****Qǐ xuǎnzé yī tí mù.**

1. **Introduce yourself (name, age, where you live).**

Jièshào nǐ zìjǐ (míngzi, niánlíng, zhù zài nǎlǐ).

OR

2. **Introduce your family and their occupations.**

Jièshào nǐ de jiārén hé tāmen de zhíyè.**Write 8–10 complete sentences in pinyin.****Qǐ xiě 8–10 gè wánzhěng jùzi (yòng pīn yīn).**

COMPETENCE BASED EDUCATION

GRADE 7 2026

FORMATIVE ASSESSMENT



NAME: _____ ASSESSMENT NUMBER: _____

SCHOOL: _____ DATE: _____

GERMAN

TIME: 1 HOUR 40 MINUTES

1. Match the German greetings with their English meanings. (5 marks)

- | | |
|-----------------|----------------|
| a) Guten Morgen | Good morning |
| b) Guten Tag | How are you? |
| c) Guten Abend | Goodbye |
| d) Tschüss | Good afternoon |
| e) Wie geht's? | Good evening |

2. Lies den Text und beantworte die Fragen. (5 Punkte)

Mary ist Schülerin. Sie ist in der sechsten Klasse. Thomas ist auch Schüler. Er ist in der achten Klasse. Sie gehen zur Heshima Akademie. Mary ist dreizehn Jahre alt und Thomas ist vierzehn Jahre alt.

a) Wer ist das Mädchen im Text?

b) Wer ist der Junge im Text?

c) Wie heißt die Schule von Mary und Thomas?

d) Schreibe in Ziffern:

Achtzig _____

Hundert _____

Dreiundsechzig _____

3. Write the following numbers in **German words**. (5 marks)

- a) 7 _____
 b) 12 _____
 c) 20 _____
 d) 15 _____
 e) 30 _____

4. Write the numbers in **figures**. (5 marks)

- a) acht _____
 b) vierzehn _____
 c) zweiundzwanzig _____
 d) neun _____
 e) dreißig _____

5. Setze die richtige Form der Verben (sein, haben, sprechen) ein.

Verwende: (ist, spreche, hast, bin, haben) (5 Punkte)

- a) Ich _____ Schüler / Schülerin.
 b) Sie _____ meine Schwester.
 c) Du _____ zehn Stühle.
 d) Wir _____ drei Stifte.
 e) David _____ Swahili und Englisch.

6. Ordne die Wörter zu richtigen Sätzen. (5 Punkte)

- a) wohne / Nairobi / in / ich
-

- b) fünfzehn / ich / Jahre / alt / bin
-

c) Jane / heißt / sie

d) Fisch / esse / ich

e) Schule / geht / in / er / die

7. Wie spät ist es? Schreibe die Uhrzeit in Worten. (4 Punkte)

12:00 _____

8:30 _____

5:25 _____

09:05 _____

8. Schreibe einen Aufsatz über dich selbst auf Deutsch. (10 Punkte)

9. Read the passage and answer the questions.

Hallo! Ich heie Anna. Ich bin zwlf Jahre alt. Ich wohne in Nairobi. Ich spreche Englisch, Swahili und ein bisschen Deutsch. Mein Freund heit Leo.

1. Wie alt ist Anna? _____ (2 marks)
2. Wo wohnt Anna? _____ (2 marks)
3. Welche Sprachen spricht Anna? _____ (3 marks)
4. Wie heit Annas Freund? _____ (2 marks)

COMPETENCE BASED EDUCATION

GRADE 7 2026

FORMATIVE ASSESSMENT



NAME: _____ ASSESSMENT NUMBER: _____

SCHOOL: _____ DATE: _____

ISLAMIC RELIGIOUS EDUCATION

TIME: 1 HOUR 40 MINUTES

1. Name five obligations of children to their relatives. (10 marks)

- a. _____
- b. _____
- c. _____
- d. _____
- e. _____

2. During a class discussion, learners were asked to **explain the importance of congregational prayers**. Write the correct explanations given by learners. (10 marks)

- a. _____
- b. _____
- c. _____
- d. _____
- e. _____

3. Muhammad, a Grade 7 learner, was invited by a Grade 6 learner to discuss the difference between **Zakat and Sadaqa**. Assist Muhammad by preparing relevant points for the lesson. (10 marks)

| Zakat | sadaqa |
|-------|--------|
| | |
| | |

4. **State five reasons why shirk is forbidden** in Islam. (5 marks)

- a. _____
- b. _____
- c. _____
- d. _____
- e. _____

5. **Name five categories of people exempted from fasting.** (5 marks)

- a. _____
- b. _____
- c. _____
- d. _____
- e. _____

6. During a discussion, learners described **five ways of showing kindness to Allah's creatures.** (10 marks)

- a. _____
- b. _____
- c. _____
- d. _____
- e. _____

7. **Write down five reasons why the Quran was revealed** to Prophet Muhammad (SAW). (5 marks)

- a. _____
- b. _____
- c. _____
- d. _____
- e. _____

8. Grade 7 learners from Mamboleo Junior School were asked to **search on different qualities of prophets.** Mention five points from their findings. (5 marks)

- a. _____
- b. _____
- c. _____
- d. _____
- e. _____

9. Describe five ways of applying lessons learnt from the Battle of Uhud in your daily life. (10 marks)

- a. _____
- b. _____
- c. _____
- d. _____
- e. _____

10. Explain five ways of promoting good relationships with people of other faiths according to the teachings of Islam. (10 marks)

- a. _____
- b. _____
- c. _____
- d. _____
- e. _____

COMPETENCE BASED EDUCATION

GRADE 7 2026

FORMATIVE ASSESSMENT

NAME: _____ ASSESSMENT NUMBER: _____

SCHOOL: _____ DATE: _____.

**ENGLISH
TIME: 1 HOUR 40 MINUTES****SECTION A: COMPREHENSION PASSAGE (15 marks)****Read the passage below and answer the questions that follow:**

The vigorous campaigns done by the government have helped reduce the spread of HIV and AIDS. This is a viral disease that is spread through body fluids from an infected person to one who is not infected. The most common way of contracting the disease is through risky sexual behavior and indiscriminate sex. The youth have been warned repeatedly to avoid pre-marital sex. Most have heeded the advice, hence the reduction in transmission. However, middle-aged people and those in marriage are now at higher risk of infection. Once infected, foreign bodies are introduced into the person, fighting the white blood cells, which help fight diseases. Once weakened, the body is exposed to all types of infections, a condition known as lack of immunity. The person's body wastes away, causing weight loss.

Cultural practices such as wife inheritance have contributed to the spread of the virus. The government has strengthened efforts to boost immunity of infected persons with ARVs available in public hospitals, which prolongs their lives. Discrimination against the sick has been controlled. The public has been educated that the disease is not easily communicable and that abstaining from irresponsible sexual behavior is important. Victims are advised on proper diet to prevent deficiency diseases and to maintain body strength. Proper exercise has also been introduced to such victims.

1. Vigorous campaigns as used in the passage means? (1 mark)

2. HIV and AIDS can be described as? (2 marks)

3. There is a decrease in the spread of the virus mainly because? (1 mark)

4. According to the passage, once one is infected? (1 mark)

5. Lack of immunity as used in the passage means? (2 marks)

6. To fight infection, AIDS patients have been advised to? (1 mark)

7. How does proper diet help the AIDS patient? (2 marks)

8. The word "reduction" as used in the passage means? (1 mark)

9. From the passage, HIV and AIDS is spread through? (2 marks)

10. Suggest the best title for the passage. (2 marks)

SECTION B: ORAL SKILLS

1. Give synonyms for the following words: (2 marks)

a) Big: _____

b) Brave: _____

2. Give antonyms for the following words: (2 marks)

a) Rough: _____

b) Calm: _____

3. Underline the **silent letters** in the following words: (4 marks)

a) Debt

b) Comb

c) Island

d) Psychology

4. Write words that are pronounced the same as the following: (2 marks)

a) Blue: _____

b) Hour: _____

SECTION C: POETRY**Read the poem below:****Wonders** – By Rehema Kwamboka Arege

As I wake up in the morning,
I hear their melodious songs.
As they cheerfully chirp in chorus,
It makes me feel happy.
As I look out of the window,
I see some flying in the sky.
As their beautifully colored feathers flap,
Scaring in the morning sun.

1. Who is the poet? (1 mark)

2. What is the main idea of the poem? (2 marks)

3. What time of day is described in the poem? (2 marks)

4. What is the title of the poem? (1 mark)

5. How many stanzas does the poem have? (1 mark)

6. How many lines does each stanza have? (1 mark)

7. Give a synonym for the word "happy" as used in the poem. (1 mark)

8. What is the meaning of the phrasal verb "look out"? (1 mark)

SECTION D: GRAMMAR

1. Underline the type of noun in brackets: (4 marks)
 - a) David gave the blanket to me. (Proper)
 - b) There are desks in the class. (Common)
 - c) Wangui has a lot of intelligence. (Abstract)
 - d) She is preparing sorghum. (Concrete)
2. Identify the tense of the following sentences (simple present or simple past): (2 marks)
 - a) I go home every day.: _____
 - b) They did their homework. : _____
3. Use the words in brackets in their comparative or superlative forms: (3 marks)
 - a) My bicycle is _____ than yours. (expensive)
 - b) She is the _____ of them all. (pretty)
 - c) It was the _____ session I have ever attended. (boring)
4. Identify the type of adverb underlined in the following sentences: (2 marks)
 - a) We arrived early for the trip. : _____
 - b) We played in the field. : _____
5. Classify the following nouns as count or non-count nouns: (4 marks)

Books, water, rice, desks, pencil, porridge, ink, ducks

| Count nouns | Non count nouns |
|-------------|-----------------|
| | |
| | |

SECTION E: WRITING

Write an interesting composition on the following title: (15 marks)

A FATAL ACCIDENT

COMPETENCE BASED EDUCATION

GRADE 7 2026

FORMATIVE ASSESSMENT



NAME: _____ ASSESSMENT NUMBER: _____

SCHOOL: _____ DATE: _____

INTEGRATED SCIENCE THEORY

TIME: 1 HOUR 40 MINUTES

Answer all questions in the spaces provided

1. List three components of integrated science: (3 marks)

i. _____ ii. _____ iii. _____

2. List three importance of learning integrated science: (3 marks)

i. _____

ii. _____

iii. _____

3. a) List four differences between luminous and non-luminous flame: (4 marks)

| Luminous Flame | Non-Luminous Flame |
|----------------|--------------------|
| | |
| | |
| | |
| | |

b) Why is a non-luminous flame preferred for heating in the laboratory? (1 mark)

4. Identify the meaning of the following hazard symbols: (3 marks)



i



ii



iii

i. _____

ii. _____

iii. _____

5. a) Identify three derived quantities: (3 marks)

i. _____

ii. _____

iii. _____

b) Complete the table below to show quantities and their SI units: (4 marks)

| Quantity | SI Unit |
|---------------------|---------|
| Temperature | |
| | Seconds |
| Amount of substance | |
| | Candela |

6. During a practical lesson, grade 7 learners wanted to measure a fixed volume of liquid for an experiment.

Identify **two apparatus** used to measure fixed volume of liquid in the laboratory: (2 marks)

i. _____

ii. _____

7. a) What is a laboratory? (1 mark)

b) Write four safety measures learners observe when using a laboratory: (4 marks)

i. _____

ii. _____

iii. _____

iv. _____

8. The diagram below shows a laboratory apparatus:

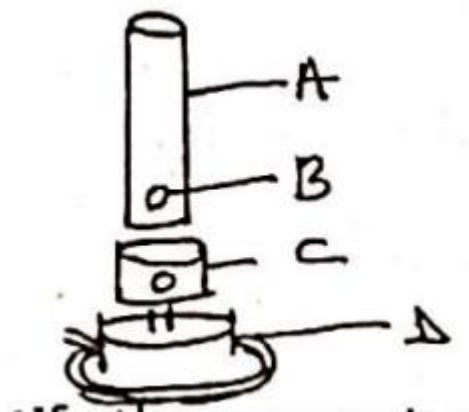

a) Identify the apparatus: _____ (1 mark)

b) Name the parts labeled A, B, C, D: (2 marks)

A: _____

B: _____

C: _____

D: _____

9. Calculate the **area of a rectangle** whose length is 15 cm and width is 10 cm. Give your answer in SI units. (3 marks)

10. Identify **two apparatus used for magnification** in the laboratory: (2 marks)

i. _____

ii. _____

11. Give **two reasons why most laboratory apparatus are made of glass**: (2 marks)

i. _____

ii. _____

COMPETENCE BASED EDUCATION

GRADE 7 2026

FORMATIVE ASSESSMENT



NAME: _____ ASSESSMENT NUMBER: _____

SCHOOL: _____ DATE: _____

INTEGRATED SCIENCE PRACTICAL

TIME: 1 HOUR 40 MINUTES

Answer all questions in the spaces provided

SECTION A: LABORATORY TOOLS & SAFETY (6 Marks)

1. Identify the following laboratory apparatus and write their names. (3 marks)

a)

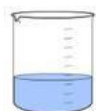

b)



c)



2. Match the safety equipment with its correct use. (3 marks)

| Equipment | Use |
|---------------|-----------------------------|
| Goggles | Protect eyes from chemicals |
| Fire blanket | |
| First aid kit | |

SECTION B: MICROSCOPE & BUNSEN BURNER (6 Marks)

1. Label the parts of the microscope below. (3 marks)

Parts to label: Eyepiece, Objective lens, Stage



2. Write one function of each part of the Bunsen burner: (3 marks)

| Part | Function |
|--------------|----------|
| Needle valve | |
| Collar | |
| Base | |

SECTION C: SCIENTIFIC SKILLS & MEASUREMENTS (6 Marks)

1. State two derived quantities used in science and give their units. (3 marks)

i. _____

ii. _____

2. State two other quantities (not derived) and give their units. (3 marks)

i. _____

ii. _____

SECTION D: SEPARATION OF MIXTURES (6 Marks)

1. Name one method used to separate: (3 marks)

a) Salt from water _____

b) Sand from water _____

c) Oil from water _____

2. In an experiment, you need to separate iron filings from sand. Name the tool you would use. (1 mark)

3. Name two rules to be followed while in a Science laboratory? (2 marks)

SECTION E: CARE AND USE OF APPARATUS (6 Marks)

1. List two ways to take care of laboratory apparatus. (2 marks)

i. _____

ii. _____

2. Explain why it is important to clean glassware after use. (2 marks)

3. Give two proper ways of handling a microscope. (2 marks)

i. _____

ii. _____

ELIMU MSINGI KWA MISINGI YA UMAHIRI

GREDI 7 2026

TATHMINI ENDELEVU



JINA: _____ NAMBARI YA TATHMINI: _____

SHULE: _____ TAREHE: _____

KISWAHILI

MUDA: SAA 1 DAKIKA 40

SEHEMU YA A: UFAHAMU (AL. 10)

Soma kifungu kifuatacho kisha ujibu maswali 1–10.

Dawa iliyovumbuliwa nchini **Zaire** ya kutibu ugonjwa mbaya wa ukimwi si madai tu. Majaribio yameonyesha kwamba huenda ikawa tiba muhimu zaidi mwishowe ya ukimwi.

Mmoja wa matibabu wa Zaire, **Profesa Mbawa Kalengayi**, ambaye alihudhuria mkutano wa **Shirika la Wanasayansi wa Africa** mjini Nairobi, alisema kwamba wagonjwa wa ukimwi wanaotibiwa na dawa hiyo ya **MMI**, wanaishi muda mrefu zaidi ikilinganishwa na wale wasiopata dawa hiyo ambao wanakufa haraka.

Profesa Kalengayi, aliye **Rais wa Shirika la Africa la Utafiti na Mafunzo juu ya Saratani**, alieleza kwamba miongoni mwa wagonjwa 25 wenye ukimwi waliotibiwa kwa dawa ya MMI, ni mmoja pekee aliyekufa. Chanzo cha kifo cha mmoja huyo kilikuwa ni maradhi ya aina moja ya saratani iliyosababisha avunje damu kwa wingi. Wagonjwa wenye ukimwi ambao hawakutibiwa na dawa hiyo wamekufa wote. Uchunguzi ulifanywa kwa wagonjwa 45, alisema Profesa Kalengayi alpowasili Nairobi baada ya kuhudhuria mkutano wa kimataifa uliofanyika Stockholm, Sweden juu ya ukimwi.

Alisema wagonjwa wanaotibiwa kwa dawa hiyo **himarika miili yao** na hata kupata uwezo wa kujikinga na maradhi mengine. Ukimwi wenyewe si ugonjwa, isipokuwa viini vyake hudhoofisha uwezo wa miili kujikinga na magonjwa; mwishowe mtu huuawa na maradhi mengine.

Dawa ya MMI ilivumbuliwa na **Profesa Luvhuma Zilimwebagabo wa Zaire** na **Dkt. Ahmed Shakif wa Misri**, lakini dawa hiyo haijatambuliwa sana kimataifa. Katika bara la Africa lenyewe, ni Tanzania pekee iliyoagiza wataalamu wake waichunguze zaidi hivi karibuni.

1. Dawa iliyovumbuliwa Zaire huenda ikawa

2. Profesa Kalengayi ni raia wa nchi gani?

3. Mkutano wa Shirika la Wanasayansi wa Africa ulifanyika nchini

4. Dawa inayozungumziwa inaitwa

5. Miongoni mwa wagonjwa 25 waliotibiwa kwa dawa hii, wangapi waliendelea kuishi?

6. "Avunje damu kwa wingi" ni sawa na

7. Ni wagonjwa wangapi hawakutibiwa?

8. Maneno "huimarika miili yao" yametumika katika taarifa. Maana yake ni:

A) Miili hupata nafuu kidogo

B) Hufa kwa kumalizika

C) Hukonda sana

D) Huu wagonjwa

9. Mkutano wa kimataifa ulifanyiwa mjini

10. Wavumbuzi wa MMI walitoka _____

SEHEMU YA B: MATUMIZI YA LUGHA

1. Andika matumizi **tatu ya alama ya kikomo** katika matini. (al. 3)

- i. _____
 ii. _____
 iii. _____

2. Soma kifungu kifuatacho kisha utambue **nomino za pekee** na **nomino za kawaida**:

Ninasoma katika Shule ya Msingi ya Kaloleni. Mpira tutacheza uwanjani huku tukila chakula cha maana. Nchi ya Tanzania ni ya kwanza katika Africa Mashariki kuwa na Rais wa kike. Mji wa Naivasha unavivutio vingi vya watalii. Simu ya baba ilipasuka.

- i) Nomino ya kawaida (al. 2) _____
 ii) Nomino ya pekee (al. 2) _____

3. Andika maneno yenye sauti hizi: (al. 2)

- i) Dh- _____
 ii) Th- _____

4. Kamilisha sentensi zifuatazo kwa kutumia **nomino sahihi**: (al. 3)

- a) Mama alikokota _____ la kuni na kulibeba.
 b) Mwanafunzi alifungulia _____ cha funguo katika suruali yake.
 c) Bi. Harusi alitunzwa na _____ la maua na wageni kutoka ng'ambo.
5. Eleza vipengele viwili vinavyostahili kuzingatiwa katika **kusikiliza na kujibu mazungumzo**. (al. 2)

- i. _____
 ii. _____

6. Eleza maana ya **nomino dhahania** kisha utoe mfano mmoja. (al. 2)

7. Andika maneno haya katika nyakati sahihi: (Ujao, Masharati, Uliopo, Uliopita)

a) Analima _____

b) Nilinunua _____

c) Nitapika _____

8. Piga mstari chini ya **nomino moja ya kitenzi-jina** katika sentensi ifuatayo: (al. 1)

Kutunza mazingira ni jambo la faida.

SEHEMU YA C: FASIHI (AL. 10)

1. Andika maana ya **fasihi simulizi** na **fasihi andishi**.

2. Taja tanzu 5 za fasihi andishi. (al. 5)

a. _____

b. _____

c. _____

d. _____

e. _____

3. Andika umuhimu wa fasihi. (al. 3)

a. _____

b. _____

c. _____

SEHEMU YA D: INSHA (AL. 10)

Andika insha ya kusisimua kuhusu:

SHEREHE YA HERI YA SIKU YA KUZALIWA
